



DOW PERFORMANCE SILICONES

All-silicone product solutions simplify installation, enhance productivity

CASE STUDY: CORNISH COMMONS, CORNISH COLLEGE OF THE ARTS



A premier college for the visual and performing arts, Cornish College of the Arts' main campus is located in Seattle's popular South Lake Union neighborhood, where the 20-story Cornish Commons opened in 2015.

The new residence hall and academic building includes a unique rainscreen design featuring 3/16" thick architectural aluminum cladding on cold-form framing. The innovative building design boasts thermal performance 40% better than required by current Seattle Building Code.

The challenge

To achieve its ambitious thermal performance, the rainscreen design includes 2" continuous R-8 exterior insulation to supplement the R-32 interior batt/cavity insulation. But that created additional challenges to be compliant with the Seattle Building Code, which dictates use of insulation outboard of the metal framing. The proposed design needed an air barrier with high permeability to ensure water vapor was not trapped in the wall cavity.

Additionally, staying on schedule – in spite of challenging Seattle weather conditions – was critical. Minimizing product incompatibility issues also was important.

The solution

Ankrom Moisan Architects, Inc. selected the 100% silicone DOWSIL™ Silicone Air Barrier System to ensure enclosure airtightness performance, durability and compatibility.

City and country

Seattle, Washington

Products

The DOWSIL™ Silicone Air Barrier System

- DEFENDAIR™ 200C Air and Weather Barrier Coating**
- DOWSIL™ 791 Silicone Weatherproofing Sealant
- DOWSIL™ Silicone Transition System

Key participants

- Building Owner – Cornish College of the Arts
- Developer – Capstone Development Partners, LLC
- Architect – Ankrom Moisan Architects, Inc.
- General Contractor – Howard S. Wright
- Exterior Cladding Contractor – The Raymond Group

*Prior to February 2018, products listed were branded as Dow Corning

**The product used at that time was DOWSIL™ DefendAir 200 which is comparable to DEFENDAIR™ 200C Air and Weather Barrier Coating.



“When we learned about the option of a fluid-applied silicone air and water barrier, we realized that DEFENDAIR™ 200C Air and Weather Barrier Coating was ideal for our needs,” said Architect Eric Bressman of Ankrom Moisan Architects. “Not only did the spray-applied product simplify installation and eliminate the need for traditional membrane materials, its high permeability ensured our design’s compliance with Seattle Building Code.”

Unitized construction

To keep the project on schedule, the design called for a combination of unitized rainscreen panels and traditional construction techniques. The use of unitized panels assembled off-site in a controlled manufacturing environment enabled continued productivity, regardless of weather.

Construction of the unitized panels by The Raymond Group was facilitated by the external cladding contractor’s licensed use of a patented universal joint system (U.S. Patent 8,943,773¹), which is designed with interlocking joints that mitigate improper installation conditions that increase the risk of failure. The joint system relies on DOWSIL™ sealants for enhanced performance.

DOWSIL™ silicones were used exclusively in the panels – DEFENDAIR™ 200C Air and Weather Barrier Coating as an air barrier and DOWSIL™ 791 Silicone Weatherproofing Sealant for unit sealing. The quick cure capability of the DOWSIL™ products helped keep unit assembly on schedule. The unitized rainscreen system was used from the third floor to the 20th floor – using 30 units per floor – with approximately 50,000 square feet protected by the DOWSIL™ Silicone Air Barrier System.

¹Assigned to AGN Universal, LLC, Duvall, WA.

All-weather installation

Construction on-site was able to continue into late fall, due in part to the low-temperature installation capability of DEFENDAIR™ 200C Air and Weather Barrier Coating, which can be applied at temperatures as low as 20°F (-6°C).

“The ability to use spray-applied product was much easier,” said Jerry Jensen, Project Manager for The Raymond Group. “Its cold-weather ability allowed us to continue construction into inclement fall weather.”

In addition to the unitized rainscreen panels, on-site work totaling nearly 8,000 square feet was completed using the DOWSIL™ Silicone Air Barrier System on the first and second floors.

Confidently Build A Better Barrier – Simple. Compatible. Silicones.

Because it’s not uncommon to face challenges with varying interfacing construction materials, having a compatible all-silicone solution from Dow was appreciated and deemed advantageous.

“Having exclusively silicone products ensured compatibility,” Jensen said. “Rather than an ‘origami’ of incompatible materials around openings, having all-silicone materials simplified construction and eliminated uncertainty.

“It’s straightforward. We can get answers from a single, trusted manufacturer, without unproductive back-and-forth exchanges with multiple suppliers,” he said. “It’s helpful to have the continuity and support – and the confidence of warranty protection – from [Dow.]”

Additionally, the all-silicone compatibility of the DOWSIL™ Silicone Air Barrier System allowed materials to be applied in any order, eliminating sequencing delays and expenses.

Learn more

Dow High Performance Building solutions include proven and innovative materials for structural and protective glazing, weatherproofing, insulating glass, high-efficiency insulation, and window and door fabrication. To learn more about the DOWSIL™ Silicone Air Barrier System and other High Performance Building solutions from Dow, visit BuildaBetterBarrier.com.

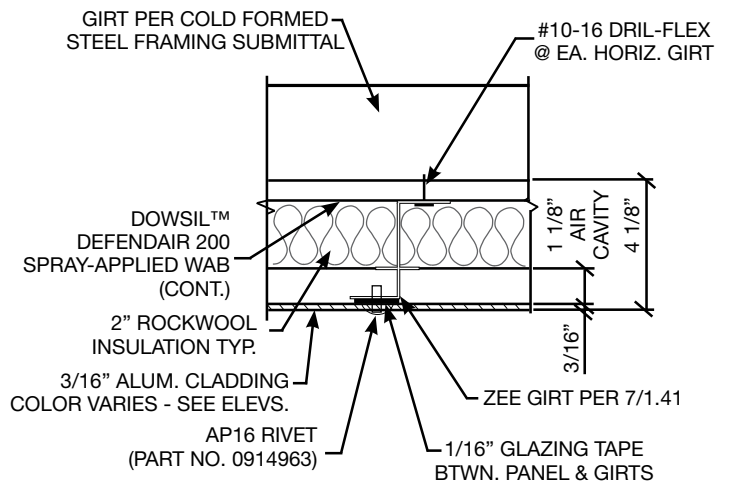
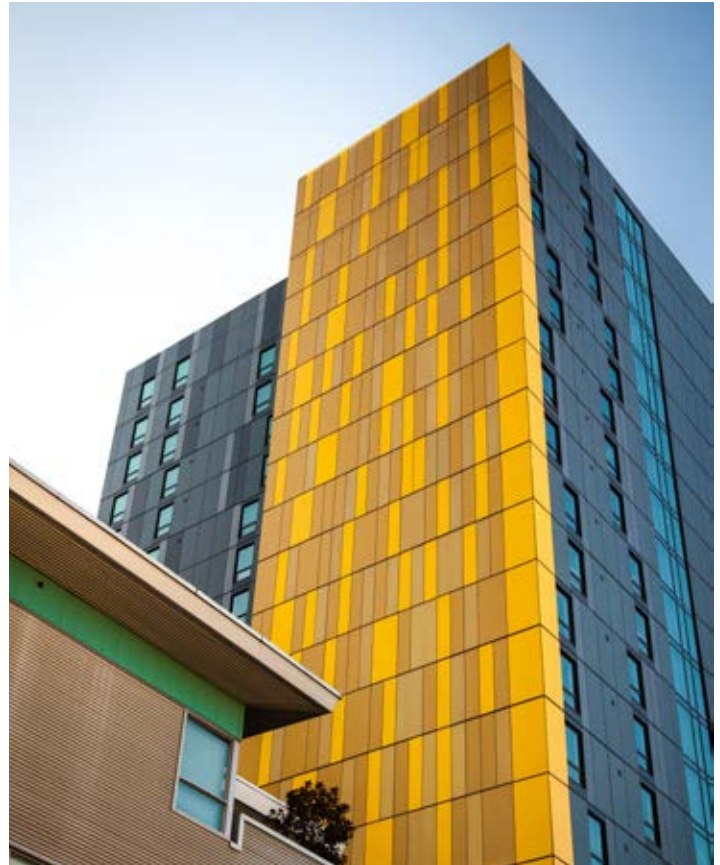

1 TYPICAL ASSEMBLY
SCALE: 3" = 1'-0"

Unitized exterior cladding panel construction includes DEFENDAIR™ 200C Air and Weather Barrier Coating as its vapor-permeable protection.

For more information

Learn more about Dow's full range of High Performance Building solutions by visiting us online at dow.com/construction.

Dow has sales offices, manufacturing sites and science and technology laboratories around the globe. Find local contact information at dow.com/contactus.

DOWSIL™

silicones by 



Dow High Performance Building website:
dow.com/construction



Contact Dow High Performance Building:
dow.com/customersupport



Visit us on Twitter
[@DowHPBuilding](https://twitter.com/DowHPBuilding)



Visit us on LinkedIn
[Dow High Performance Building](https://www.linkedin.com/company/dow-high-performance-building)

Images: dow_43184119849, dow_43184119704 (Photos courtesy of Ankrom Moisan Architects and photographer Casey Braunger. © Ankrom Moisan Architects.)

PRODUCT SAFETY INFORMATION REQUIRED FOR SAFE USE IS NOT INCLUDED IN THIS DOCUMENT. BEFORE HANDLING, READ PRODUCT AND SAFETY DATA SHEETS AND CONTAINER LABELS FOR SAFE USE, PHYSICAL AND HEALTH HAZARD INFORMATION. THE SAFETY DATA SHEET IS AVAILABLE ON THE DOW WEBSITE AT WWW.DOW.COM, OR FROM YOUR DOW SALES APPLICATION ENGINEER, OR DISTRIBUTOR, OR BY CALLING DOW CUSTOMER SERVICE.

NOTICE: No freedom from infringement of any patent owned by Dow or others is to be inferred. Because use conditions and applicable laws may differ from one location to another and may change with time, Customer is responsible for determining whether products and the information in this document are appropriate for Customer's use and for ensuring that Customer's workplace and disposal practices are in compliance with applicable laws and other government enactments. The product shown in this literature may not be available for sale and/or available in all geographies where Dow is represented. The claims made may not have been approved for use in all countries. Dow assumes no obligation or liability for the information in this document. References to "Dow" or the "Company" mean the Dow legal entity selling the products to Customer unless otherwise expressly noted. NO WARRANTIES ARE GIVEN; ALL IMPLIED WARRANTIES OF MERCHANTABILITY OR FITNESS FOR A PARTICULAR PURPOSE ARE EXPRESSLY EXCLUDED.

®™ Trademark of The Dow Chemical Company ("Dow") or an affiliated company of Dow

© 2021 The Dow Chemical Company. All rights reserved.

2000000943

Form No. 63-6225-01-0421 S2D