

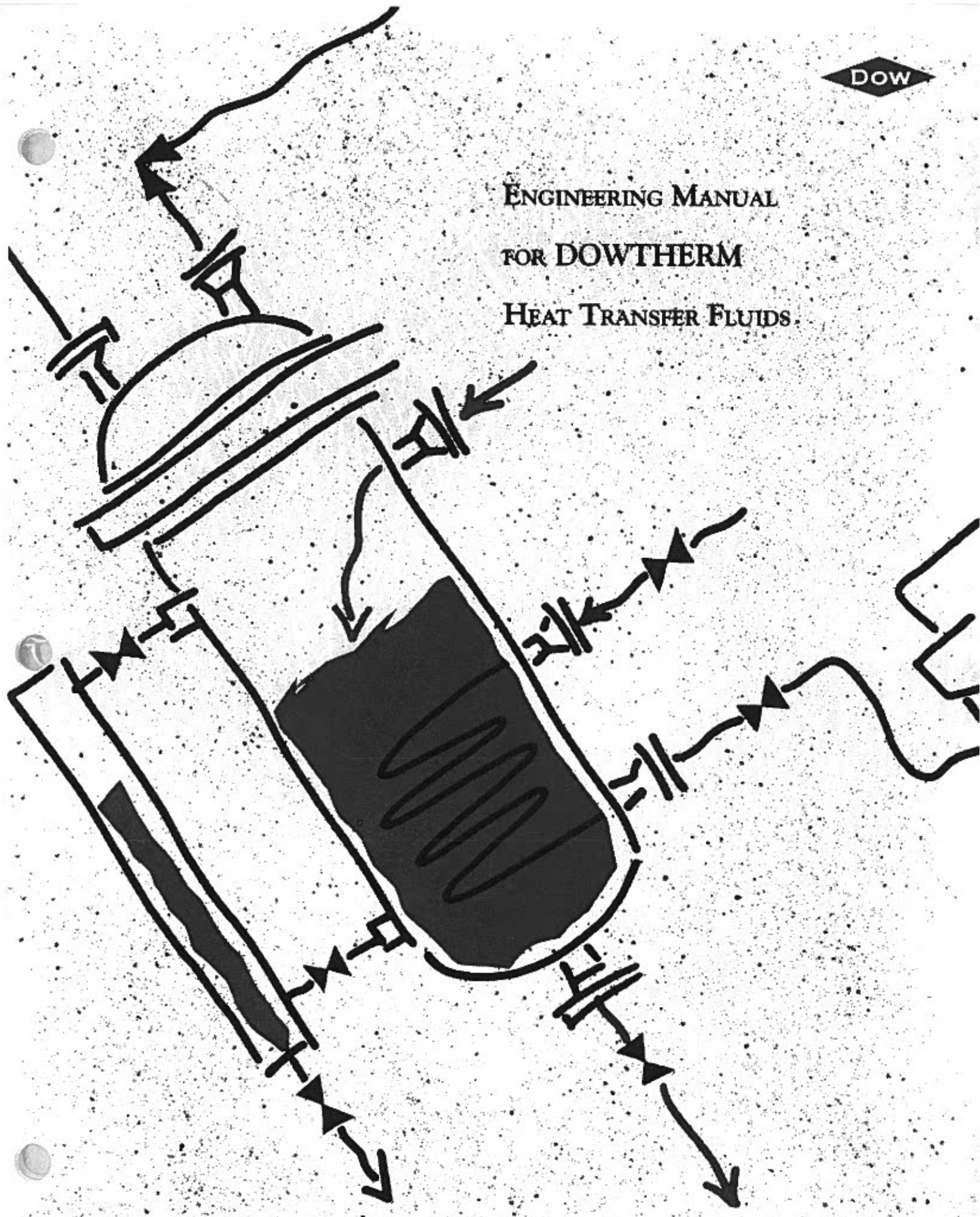

ENGINEERING MANUAL
FOR DOWTHERM
HEAT TRANSFER FLUIDS.



CONTENTS

I. INTRODUCTION	1
II. LIQUID AND VAPOR PHASE TECHNOLOGY	3
Advantages of Liquid Phase Heating with DOWTHERM	3
Advantages of Vapor Phase Heating with DOWTHERM	3
III. SYSTEMS FOR DOWTHERM	7
System Designs and Types	7
Gravity Condensate Return Systems	7
Pump Condensate Return Systems	7
Hartford Loop	8
IV. START-UP AND OPERATING FACTORS	13
Cleaning of Systems	13
Testing for Leakage	13
Contamination and Degradation	13
Contamination	13
Degradation	14
Detection of Contamination	14
Analysis and Reprocessing Service	14
V. ENGINEERING DATA AND CALCULATIONS	15
Heat Transfer	15
Heat Transfer Mechanisms	15
Process Heat Transfer	15
The Controlling Film Coefficient	16
Heat Flow Area	16
Heat Transfer Rates, Clean and Dirty	16
Logarithmic Mean Temperature Difference	16
Boiling Film Coefficients	18
Surface Area Calculations	18
Pressure Drop	23
Vaporization and Nucleate Boiling	25
General Principles of Vaporization and Nucleate Boiling	25
Types of Vaporizers	26
VI. DETERMINING DESIGN CHARACTERISTICS OF REBOILER	27
VII. GENERAL TECHNICAL DATA	33
Table 4: Steel Pipe Dimensions, Capacities, and Weights	34
Table 5: Average Properties of Tubes	35
Figure 24: Overall Heat Transfer Coefficient	36
Table 6: Industrial Design Fouling Resistance	37
Table 7: Miscellaneous Overall Heat Transfer Coefficients	37
Table 8: Thermal Resistance of Pipes and Tubing	38
Figure 25: Viscosity Conversion	39
Table 9: Heat Loss from Insulated Pipe	40
Table 10: Thermal Conductivity of Insulations	40
Figure 26: Heat Losses from Horizontal Bare Iron Surfaces	41
Figure 27: Effect of Wind Velocity on Bare or Insulated Surfaces	42
Table 11: Thermal Expansion Data	43
Figure 28: Tank Capacity Diagram	44
Table 12: Horizontal Cylindrical Tank Volumes	45
Table 13: Steam Table	46
Table 14: Frequently Used Engineering Conversion Factors	47



I INTRODUCTION

DOWTHERM* brand heat transfer fluids were developed by The Dow Chemical Company for use at high temperatures when the use of steam or hot water is not practical. The fluids transfer heat energy typically between 500°F and 750°F, where the alternatives—direct fire, electrical conduction, and hot water/steam—are considered unsafe, uneconomical, or incompatible with the process.

Six products are currently available: **DOWTHERM A**, **DOWTHERM G**, **DOWTHERM J**, **DOWTHERM LF**, **DOWTHERM HT**, and **DOWTHERM Q** heat transfer fluids.

DOWTHERM A heat transfer fluid is the most widely used product. This product, first introduced in 1929, is a eutectic mixture of two very stable organic compounds, diphenyl ($C_{12}H_{10}$) and diphenyl oxide ($C_{12}H_{10}O$). These two compounds have practically the same vapor pressures, so the mixture can be handled as if it were a single compound. **DOWTHERM A** heat transfer fluid may be used in systems employing either vapor or liquid heating. The recommended temperature use range is 60°F to 750°F (16°C to 400°C), and the corresponding vapor pressure range is from atmospheric to 138 psig.

DOWTHERM G heat transfer fluid is a specially formulated mixture of aryl ethers designed for use in liquid systems. These systems may operate at lower pressures than with **DOWTHERM A** fluid. The recommended temperature range is 20°F to 700°F (-7°C to +371°C), and the corresponding vapor range from atmospheric to 40 psig.

DOWTHERM J heat transfer fluid is an alkylated aromatic which, like **DOWTHERM A**, can be used for both liquid-phase and vapor phase heating. Its recommended temperature use range is -100°F to +600°F (-73°C to +315°C), and its pressure range is from atmospheric to 135 psig.

DOWTHERM LF heat transfer fluid is an aromatic blend which is used for liquid phase heating. Its recommended use range is -40°F to +650°F (-40°C to +343°C). Use of this medium reduces the need for steam tracing of piping and valves.

DOWTHERM HT heat transfer fluid displays good thermal stability characteristics across its entire use range of 25°F to 650°F (-3°C to +343°C). Its principal advantage is its high boiling point (650°F) allowing for low system operating pressures. It is low in toxicity, possesses only faint odor characteristics and is non-corrosive to metals commonly used in heat transfer systems.

DOWTHERM Q heat transfer fluid is a high performance alternative to hot oils. Its recommended use temperature range is -30°F to +625°F (-34°C to +329°C). The fluid combines high temperature stability with low

temperature pumpability—a combination hot oils can't match. Because of its superior thermal stability, this fluid can offer substantial economic savings over the life of your heat transfer project.

If these fluids are used above their recommended upper temperature, greater thermal degradation will occur. Over the years, **DOWTHERM** heat transfer fluids have been adopted for an almost countless number of applications, and today's user can purchase heat transfer equipment from a variety of engineering firms and equipment manufacturers.

The Dow Chemical Company and its associated companies make extensive use of **DOWTHERM** heat transfer fluids in their own operations. The heaters and vaporizers employed range from laboratory units rated at 1000 Btu/hr to large units of 100 million Btu/hr. The ratings of most units fall between two million and 15 million Btu/hr. Units are heated by burning gas, oil, and coal, as well as by electricity. Also, in certain operations, **DOWTHERM** fluids can be heated by high pressure steam. This latter technique is used on jacketed vessels where pressure limitations require the low pressure of **DOWTHERM** fluids.

One of the first large vaporizers using **DOWTHERM A** fluid was installed in 1930 and was operated continuously until 1974. This was a multiple drum type unit with the fluid circulating by thermosiphon action in the tubes. The Dow Chemical Company's experience with its many units, as well as the experience of its customers, has shown dramatically that properly designed, instrumented, maintained, and operated units using **DOWTHERM A** fluid provide many years of safe, dependable, efficient operation.

This bulletin provides information that pertains generally to all **DOWTHERM** fluids. It includes sections on liquid and vapor phase technology, system designs, startup and operational factors, and engineering calculations. Separate bulletins on each **DOWTHERM** fluid with more specific product technical information are available upon request, as are equipment and safety bulletins. For convenience, the use ranges and other significant characteristics of the individual products are provided in Figure 1 and Table 1. In addition, Dow technical personnel are available to consult with customers on the design and engineering of heat transfer systems, as well as on any operating problems that might arise.

Note: "Material Safety Data Sheets" and a Health, Environmental and Safety Considerations brochure (176-1336) that give detailed safety information are available from The Dow Chemical Company or its sales offices listed on the back cover.

* Trademark of The Dow Chemical Company

Figure 1 — Operating Ranges for DOWTHERM Heat Transfer Fluids Compared to Water

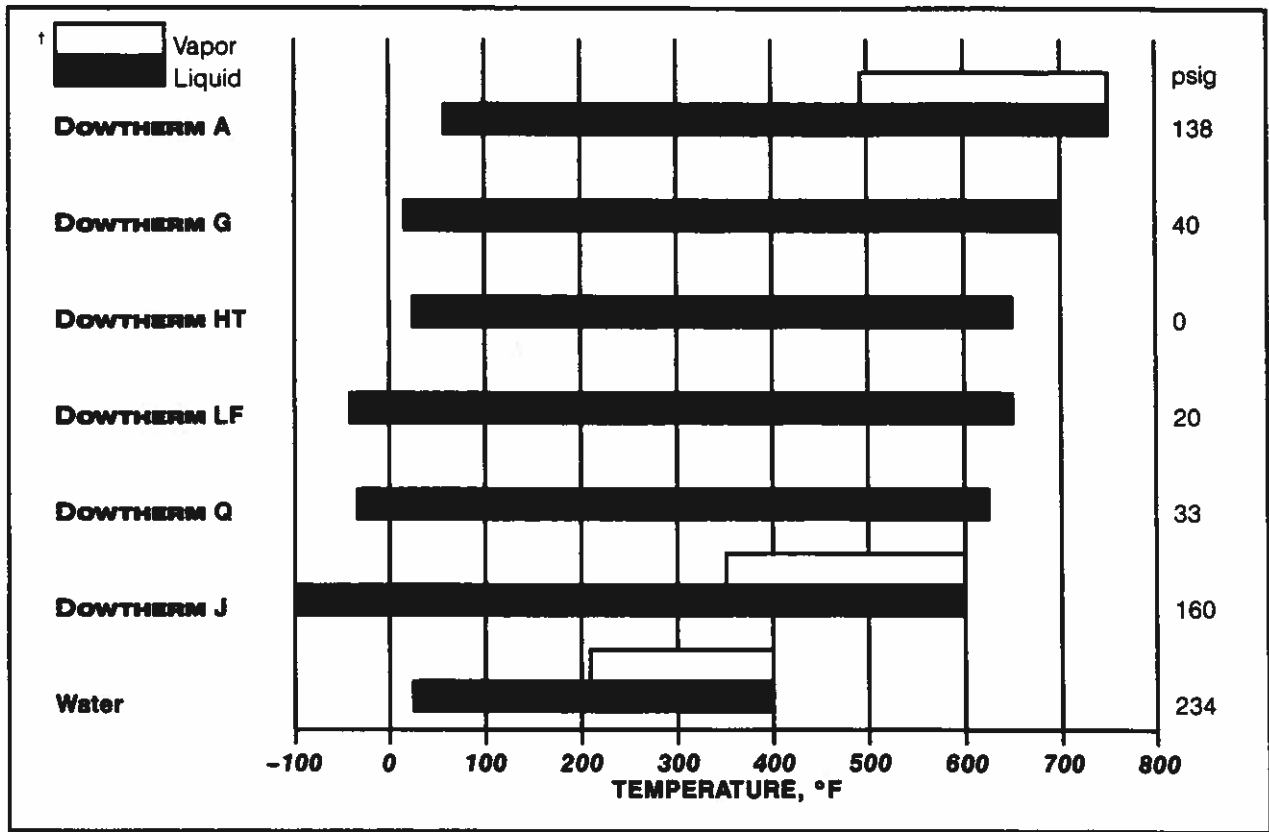

Table 1 — Significant Properties† of DOWTHERM Heat Transfer Fluids

Composition		DOWTHERM A	DOWTHERM G	DOWTHERM LF	DOWTHERM J	DOWTHERM HT	DOWTHERM Q
		73.5% Diphenyl oxide 26.5% biphenyl	Mixture of di- and tri- aryl ethers	Aromatic blend	Alkylated aromatic	Partially hydrogenated terphenyl	diphenyl ethane
Temperature Use Range, °F	Liquid	60 to 750	20 to 700	-40 to 650	-100 to 600	25 to 650	-30 to 625
	Vapor	495†† to 750	—	—	358†† to 600	—	—
Film Coefficient @ 800°F, Btu/hr ft ² °F†††		613	511	506	395	466	511
Vapor Pressure, psig	at Max. use temperature	152.02	57.64	51.01	174.52	14.17	48.08
	at Min. use temperature	0.081	0.079	0.084	0.086	0.072	0.084
Thermal Conductivity, Liquid, Btu/(hr) (ft ²) (°F/ft)	at Max. use temperature	0.055	0.054	0.051	0.037	0.061	0.048
	at Min. use temperature	0.373	0.36	0.391	0.379	0.336	0.35
Specific Heat, Liquid, Btu/(lb) (°F)	at Max. use temperature	0.634	0.57	0.606	0.721	0.656	0.62
	at Min. use temperature	4.9	148.28	397	7.96	1815	48.2
Viscosity, Liquid Centipoise	at Max. use temperature	0.13	0.21	0.22	0.16	0.33	0.19
	at Min. use temperature	66.4	70.3	66.4	58.1	63.5	63.2
Density, Liquid lb/ft ³	at Max. use temperature	42.5	51.1	47.6	35.4	48.4	45.9
	at Min. use temperature	53	-40	-40	Below -100	25	-30
Min. Pumping Temperature, °F		53	-40	-40	Below -100	25	-30
Flash Point, °F, SETA		236	266	248	136	342	249
Fire Point, °F, Cleveland Open Cup		245	275	259	140	375	255
Autoignition temperature, °F, ASTM††††		1,139	1,083	880	788	662	773

†Properties shown are typical and should not be considered specifications.

††Boiling point at atmospheric pressure.

††† ft/sec; d = 1.00

††††New ASTM Method E 659-78.

Material Safety Data Sheets for all DOWTHERM heat transfer fluids are available from your nearest Dow sales office.

II LIQUID AND VAPOR PHASE TECHNOLOGY

In choosing between liquid phase and vapor phase heating with DOWTHERM heat transfer fluids, it is necessary to consider the overall process, the heat tolerance of the product, the equipment, and the overall economics. In many cases, the overall costs for the two types of systems will not differ significantly, and the choice must be based on other considerations.

With vapor phase systems, heat is transferred at the saturation temperature of the vapor. As a result, such units can provide uniform and precisely controlled temperatures. The heating of synthetic fiber spinnerettes represents just one of the many applications that take advantage of these vapor properties.

In liquid phase systems, the temperature of the heating medium decreases as it gives up its sensible heat. Thus, the temperature of the medium at the inlet will be higher than its temperature at the outlet. This temperature change can be harmful to heat-sensitive products, even when it is reduced by increasing the circulation rate of the medium. However, for heat-insensitive products such changes in temperature are of little consequence.

In systems with multiple heat users, a combination of both vapor and liquid phase may be superior to either by itself. Economics is the deciding factor when considering line sizing, distances, pressure drop, type of equipment, method of temperature control, and temperature requirements.

Forced circulation units may be used with both liquid phase and vapor phase systems. Such units require a pump; hence, both initial and operating costs may, in some cases, be higher than equivalent costs for gravity systems with natural circulation vaporizers. However, costs should be investigated for each system, since this may not always hold true. In a liquid phase system, the pump for the forced circulation heater may be sized large enough for the entire system. If a forced circulation vaporizer is used, a pump may or may not be required to return the condensate, depending on the liquid head available.

Many systems employ DOWTHERM fluids for cooling, either by circulating it or by allowing it to boil and extracting the latent heat at a constant temperature. In addition, many use DOWTHERM fluids for heating and cooling the same piece of equipment. Where very accurate and uniform cooling is required, baffles may be placed in the jacket to direct the liquid flow, or cooling may be precisely controlled by boiling DOWTHERM heat transfer fluids at the controlled pressure.

Advantages of Liquid Phase Heating with DOWTHERM

1. Unlike vapor phase systems, those employing DOWTHERM fluids require no condensate return equipment. This factor becomes more important when there are multiple users operating at widely differing temperatures.
2. Where alternate heating and cooling are necessary, liquid phase heating allows the use of simpler, more easily operated systems.
3. There is no temperature gradient due to pressure drop in the supply piping.
4. Liquid systems give a positive flow through the user with a minimum of venting.
5. Liquid phase heating eliminates the problem of condensate removal in such units as platen presses and horizontal sinuous coils.

Figure 3 shows a liquid phase heating system employing DOWTHERM fluid.

Advantages of Vapor Phase Heating with DOWTHERM

1. Vapor phase systems provide much more heat per pound of heat transfer medium passed through the user. With DOWTHERM A fluid at 500° F, for example, 12,690 Btu/hr will be obtained by condensing 100 lbs/hr. To match this heat output using liquid medium, 2,373 lbs/hr would be required with a 10° F temperature drop or 481 lbs/hr with a 50° F temperature drop.
2. Vapor systems, with their condensing vapor, can provide a more uniform heat source and precision temperature control of the user. An equivalent liquid system would have to be operated at extreme flow rates in order to maintain the same close temperature uniformity. This is illustrated in Figure 2, page 4.
3. Vapor phase heating has an advantage where it is difficult to control liquid flow pattern and velocity; e.g. in kettle jackets.
4. No pumps are needed when a gravity return condensate system is used with a natural circulation vaporizer.
5. A vapor system requires less working inventory of DOWTHERM since the line to the user, and the user, are filled with vapor rather than liquid.
6. With heat-sensitive products, where the maximum temperature of the heat transfer medium must be limited, heating may be accomplished more economically with condensing vapor than with liquid at high mass flow rates.

Figure 4 shows a vapor phase heating system employing DOWTHERM A fluid.

Figure 2—Comparison of Liquid vs. Vapor Mass Flow Rates
for DOWTHERM A Fluid at Various Liquid ΔT 's

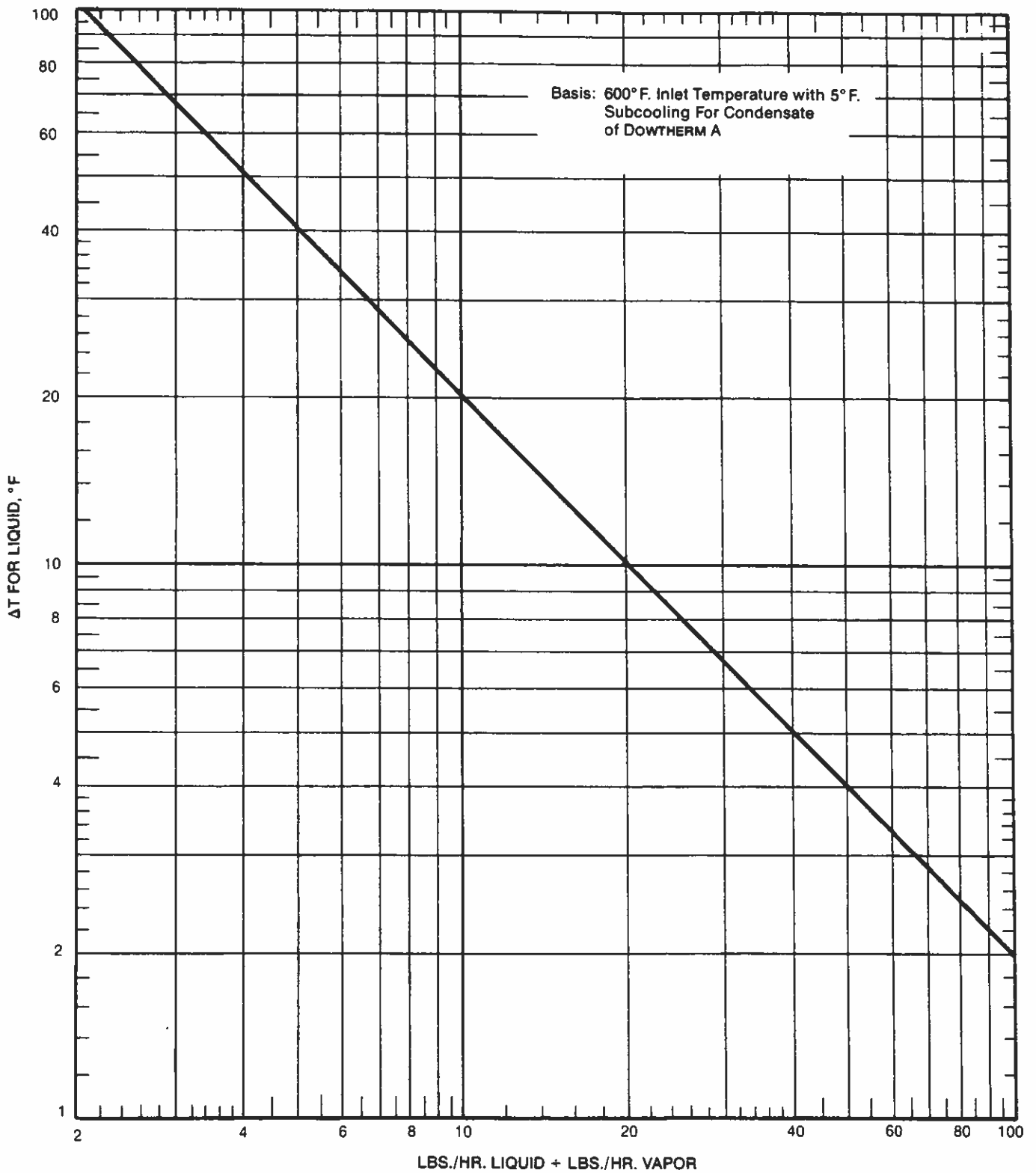
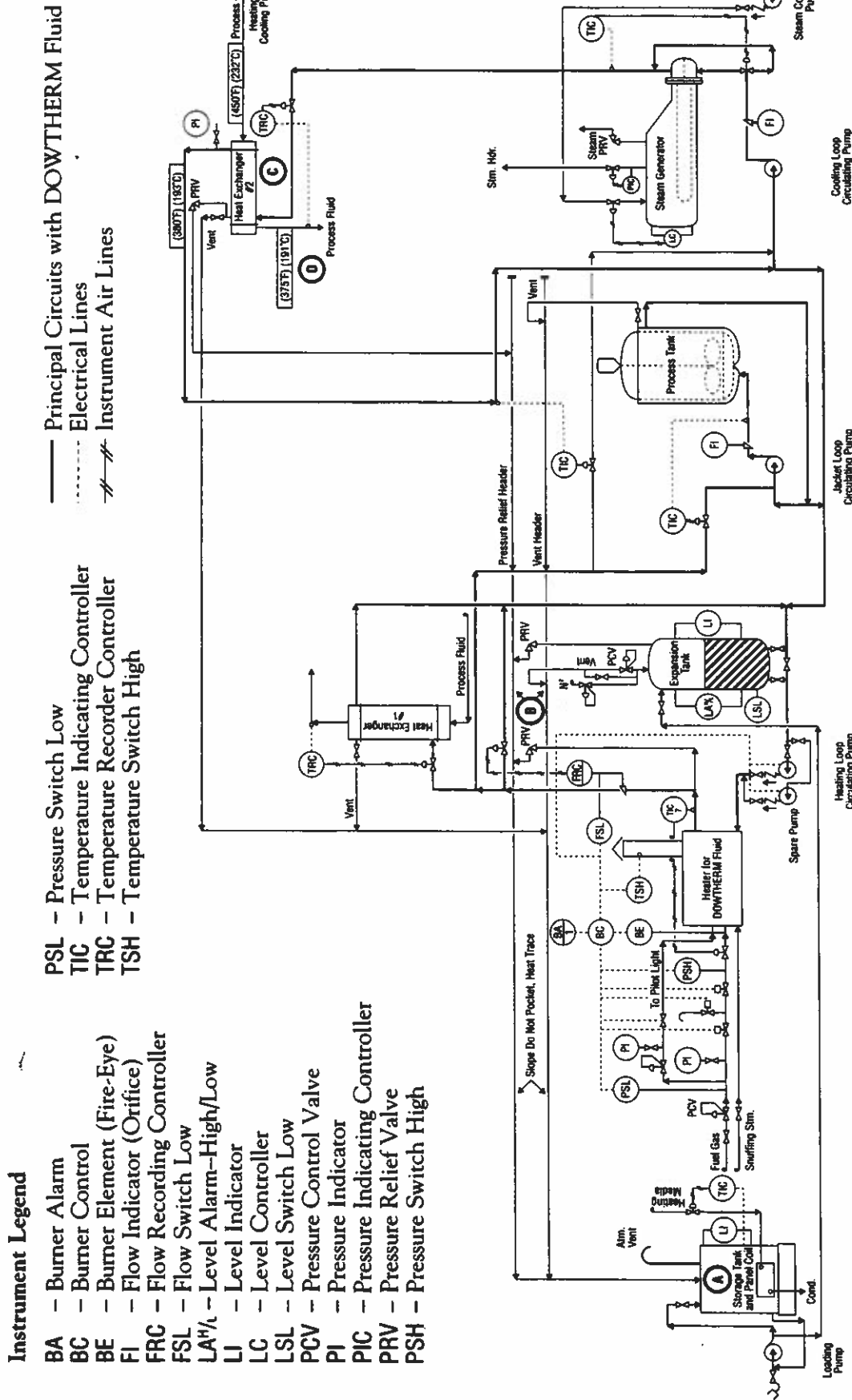

Figure 3 — Typical Liquid Phase Heating Scheme Using DOWTHERM Fluids



Instrument Legend

- BA — Burner Alarm
- BC — Burner Control
- BE — Burner Element (Fire-Eye)
- FI — Flow Indicator (Orifice)
- FRC — Flow Recording Controller
- FSL — Flow Switch Low
- LA^{H/L} — Level Alarm—High/Low
- LI — Level Indicator
- LC — Level Controller
- LSL — Level Switch Low
- PCV — Pressure Control Valve
- PI — Pressure Indicator
- PIC — Pressure Indicating Controller
- PRV — Pressure Relief Valve
- PSH — Pressure Switch High

- PSL — Pressure Switch Low
- TIC — Temperature Indicating Controller
- TRC — Temperature Recorder Controller
- TSH — Temperature Switch High

- Principal Circuits with DOWTHERM Fluid
- Electrical Lines
- Instrument Air Lines

- (A)** — External heating required if fluid pumpability is limiting in cold weather.
- (B)** — Thermal tracing system on vent and safety valve lines if ambient temperature = <80°F (27°C).
- (C)** — Heat exchanger #2 is cooled with DOWTHERM A fluid to avoid any possibility of contaminating the process fluid with water in the event of a tube leak.
- (D)** — Process fluid freezes at 350°F (177°C).

Figure 4 — Typical Vapor Phase Heating Scheme Using DOWTHERM A Fluid

- Instrument Legend**
- BA — Burner Alarm
 - BC — Burner Control
 - BE — Burner Element (Fire-Eye)
 - FI — Flow Indicator (Orifice)
 - FRC — Flow Recording Controller
 - FSL — Flow Switch Low
 - LA^{H/L} — Level Alarm—High/Low
 - LI — Level Indicator
 - LC — Level Controller
 - LSL — Level Switch Low
 - PCV — Pressure Control Valve
 - PI — Pressure Indicator
 - PIC — Pressure Indicating Controller
 - PRV — Pressure Relief Valve
 - PSH — Pressure Switch High
 - PSL — Pressure Switch Low
 - TIC — Temperature Indicating Controller
 - TRC — Temperature Recorder Controller
 - TSH — Temperature Switch High

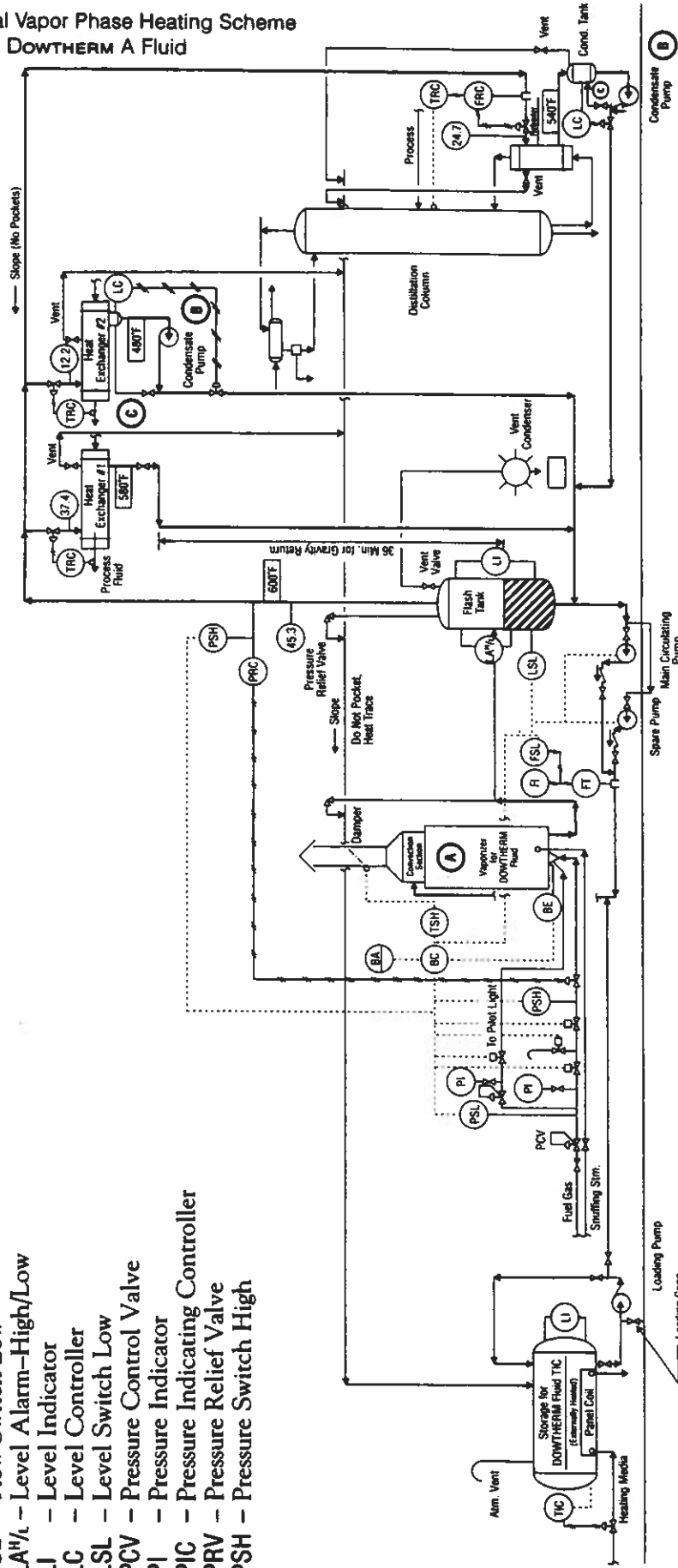

Thermal Tracing System required if ambient temperature = <60°F.

- Ⓐ — Vaporizers for DOWTHERM A fluid utilize both natural and forced circulation.
- Ⓑ — A pump is required where there is insufficient elevation between vaporizer and heat user to return condensate by gravity.
- Ⓒ — Hand-throttled bypass required to prevent pump heat-up.

III SYSTEMS FOR DOWTHERM FLUIDS

System Designs and Types

Figures 5 through 12 on pages 8 through 12, illustrate the basic designs of simple systems employing DOWTHERM heat transfer fluid.

The Dow Chemical Company is not in a position to design equipment for customer use. We suggest that such help be secured from competent engineering companies, consultants, or equipment fabricators experienced with DOWTHERM fluid.

It is also recommended that equipment be purchased only from manufacturers experienced in design and fabrication of such equipment.

The Dow Chemical Company has gained vast experience in the handling and use of DOWTHERM fluid. We are always interested in discussing potential applications or offering technical assistance for proposed systems, as well as being of service to our present customers at all times.

Gravity Condensate Return Systems

The simplest and most easily operated type of system using DOWTHERM heat transfer fluid in the vapor state is one in which the condensate from the heated equipment is returned to the vaporizer by gravity, thus providing a system without a pump. Such a system is possible if there is sufficient difference in elevation between the heat user and the vaporizer so that the static liquid head will counterbalance all friction losses in the vaporizer, vapor piping, heat user, and condensate return piping without flooding of the heated equipment. Where several pieces of equipment are operated from one vaporizer, gravity return is still possible if the same pressure is desired in each heat user and the pressure drops through all heat users are approximately the same. It is likewise possible if the static head of the lowest-pressure unit is increased to compensate for the unit having the highest pressure drop. In such cases, it is always desirable to join the condensate

return lines at the lowest possible elevation to prevent vapor by-pass or flooding of one unit by the condensate from another. Traps may also be used to accomplish the same result.

Pump Condensate Return Systems

Where there is insufficient difference in elevation between the vaporizer and the heat user, the condensate must be returned to the vaporizer by a pump. Usually, if several heated units are operating at different pressures, separate pumps should be employed. These pumps can be of the centrifugal type. If the pump is operated with a "starved" suction, a small hand-throttled by-pass valve and line is generally installed around the pump to reduce surging and cavitation. An alternative is to install a receiver between the heat users and the pump, with gravity or trap return to the receiver. The condensate in receivers is ordinarily returned to the vaporizer by a centrifugal pump operated or controlled by liquid level instrumentation. Still another common alternative is to have the liquid level instrument on the receiver open and close an automatic valve in the discharge line from the pump to the vaporizer. Again, a small by-pass line and throttle valve should be installed around the pump. In any event, an adequate NPSH should be provided for the pump. A shutoff valve should be installed between the condensate pump and the vaporizer, with the shutoff valve nearest the vaporizer.

In small systems where a single temperature is required, a positive displacement pump that is properly selected to handle the physical properties of the fluid may be used. Such a pump may be inserted in the condensate return line and run without fear of it becoming vapor bound. The pump should not run dry, as mechanical damage may occur. No traps or level controls need to be employed. It is recommended that positive displacement pumps be protected by a pressure-relieving device.

Hartford Loop

In gravity return systems where the condensate is returned to any point below the desired liquid level of the vaporizer, a Hartford Loop should be incorporated.

A Hartford Loop consists of a line without valves, located outside of the vaporizer and connecting the vapor outlet and the condensate inlet. The condensate return line is connected to the vapor-condensate line or loop at the same elevation as the lowest permissible level in the vaporizer. Thus a vacuum in the heated

equipment can then pull liquid from the vaporizer (or a closed valve in the vapor line can force liquid from the vaporizer) only until the level in the vaporizer falls to the level of this connection. After this, no more liquid can leave the vaporizer because the pressure of the vapor acts equally on the liquid in the loop and in the vaporizer. The resultant liquid hammer will give warning that the liquid level in the vaporizer is too low. The horizontal connection in the loop should not be more than two pipe diameters in length. (See Figure 5 below.)

Basic System Designs

Figure 5— DOWTHERM Fluid Used in Vapor Phase Gravity Condensate Return. System Vaporizer is Vertical Fire-Tube with Natural Circulation.

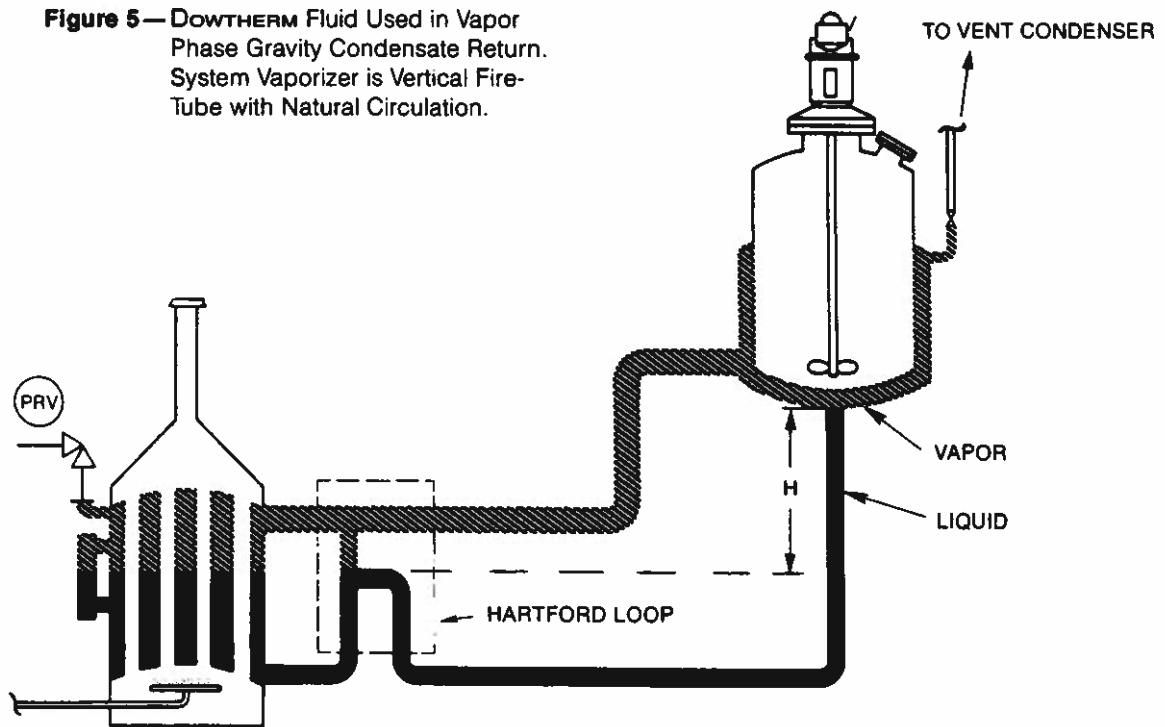

The height "H" of the liquid in the condensate line must be high enough above the vaporizer inlet to provide circulation.

Figure 6—DOWTHERM Fluid Used in Vapor Phase System with Pumped Condensate Return. Vaporizer is Horizontal Fire-Tube with Natural Circulation.

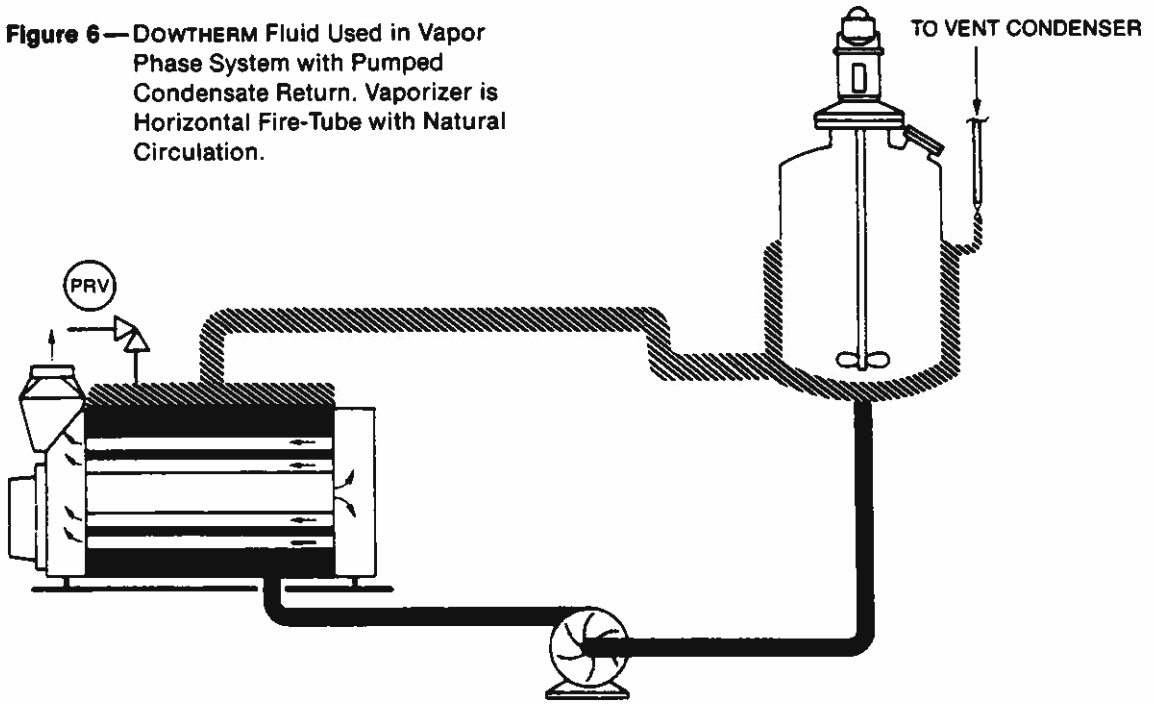

Figure 7—DOWTHERM Fluid Used in Combination Vapor and Liquid Phase Heating. Vaporizer is Liquid-Tube Type with Natural Circulation.

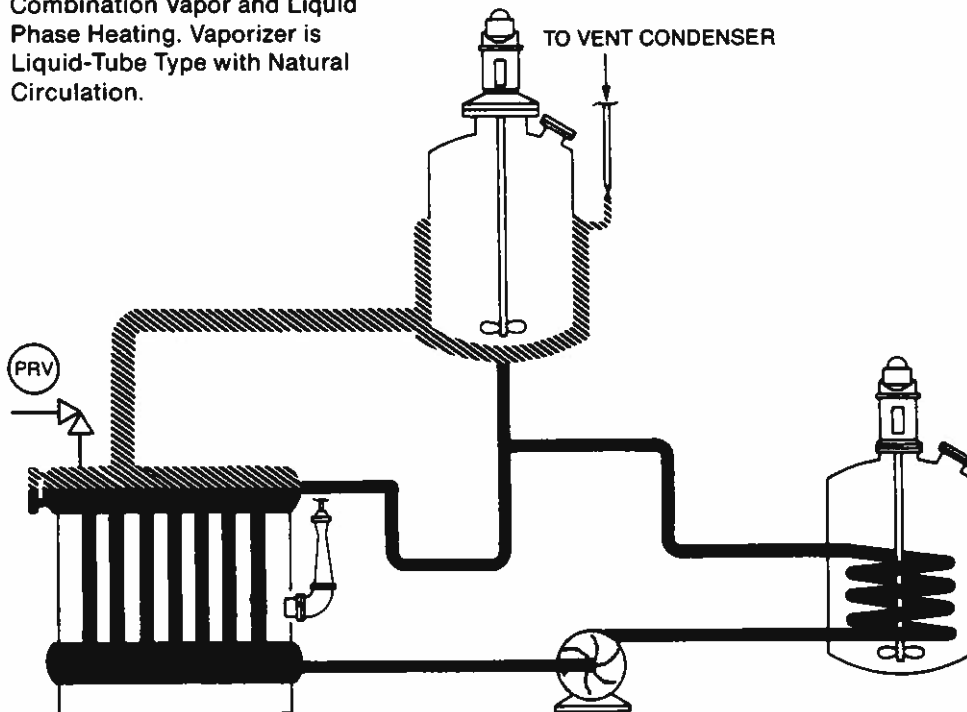

Figure 8—DOWTHERM Fluid Used in Vapor Phase System with Multiple Heat Users Operating at Different Temperatures. Vaporizer is Liquid-Tube Type with Natural Circulation.

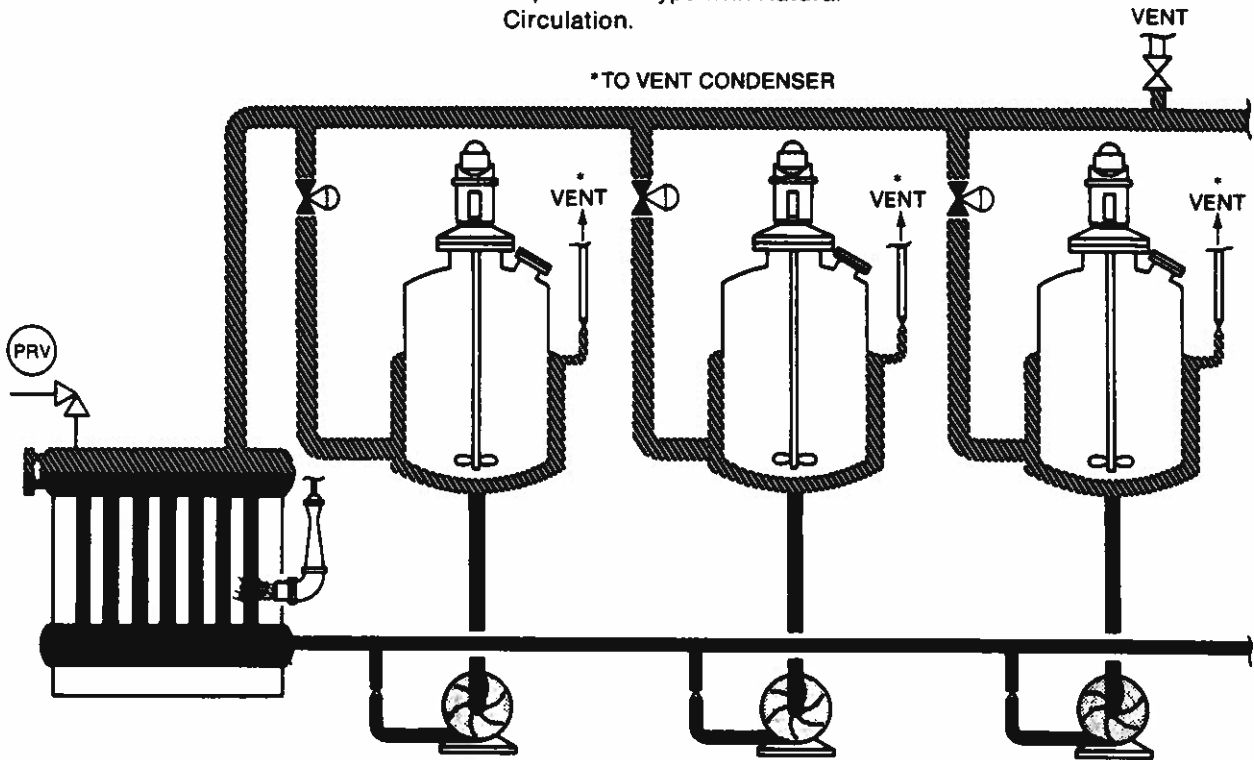

Figure 9—DOWTHERM Fluid Used in Vapor Phase with Gravity Condensate Return. DOWTHERM Fluid is Heated in Forced Circulation Heater and Flashed to Vapor in Flash Tank.

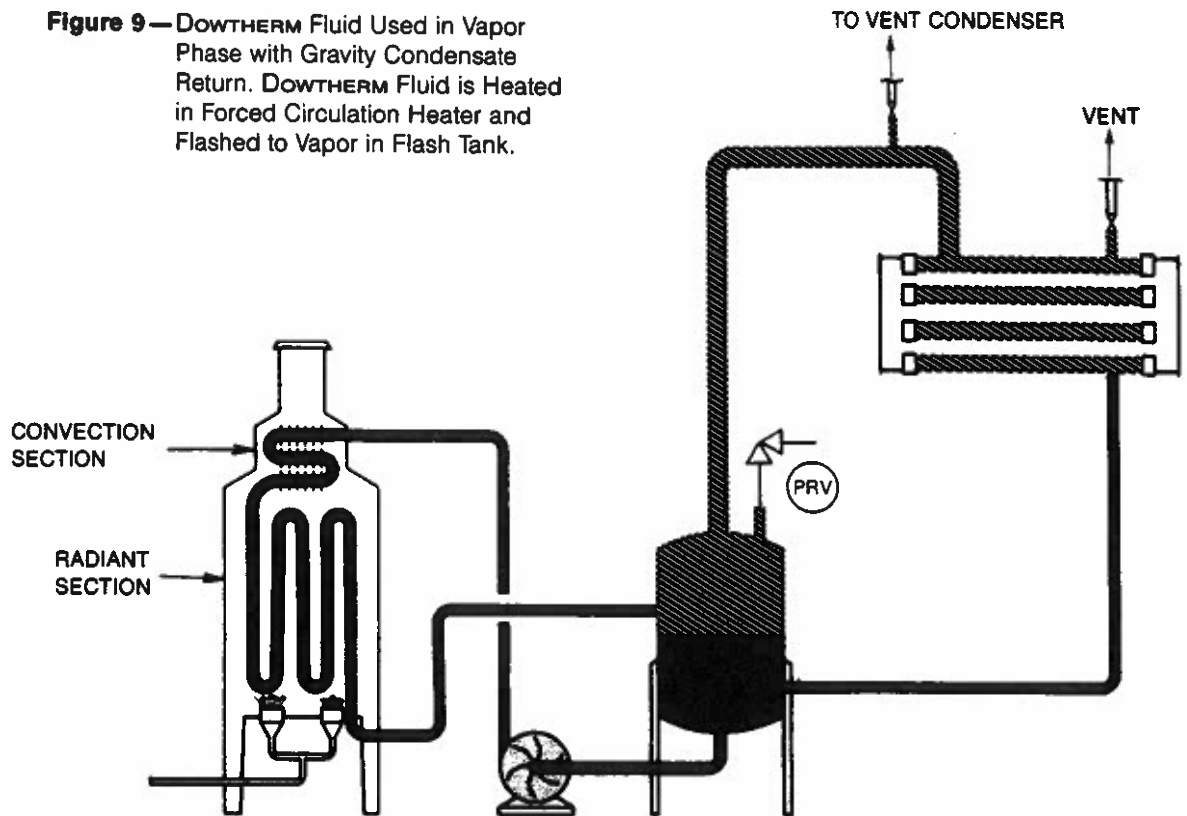

Figure 10—DOWTHERM Fluid Used in Liquid Phase with Forced Circulation Type Heater.

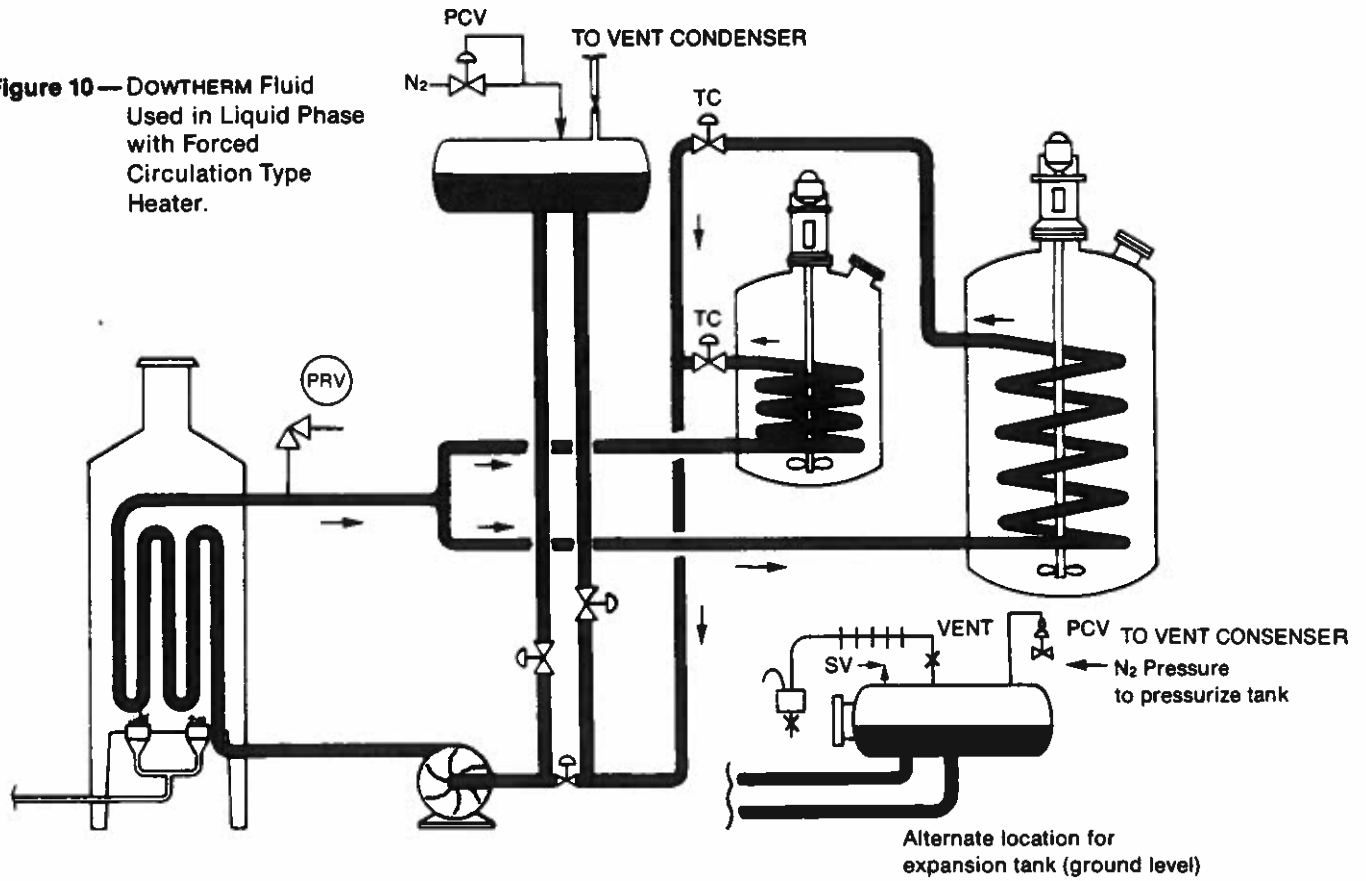
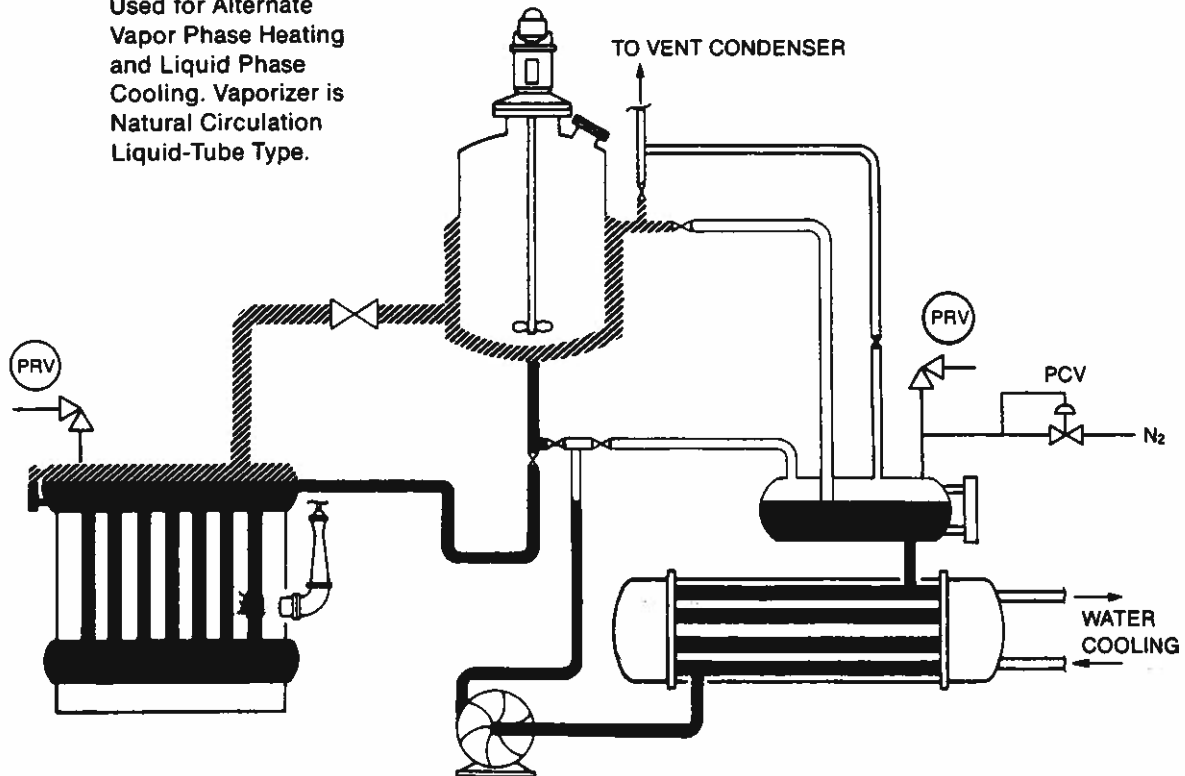
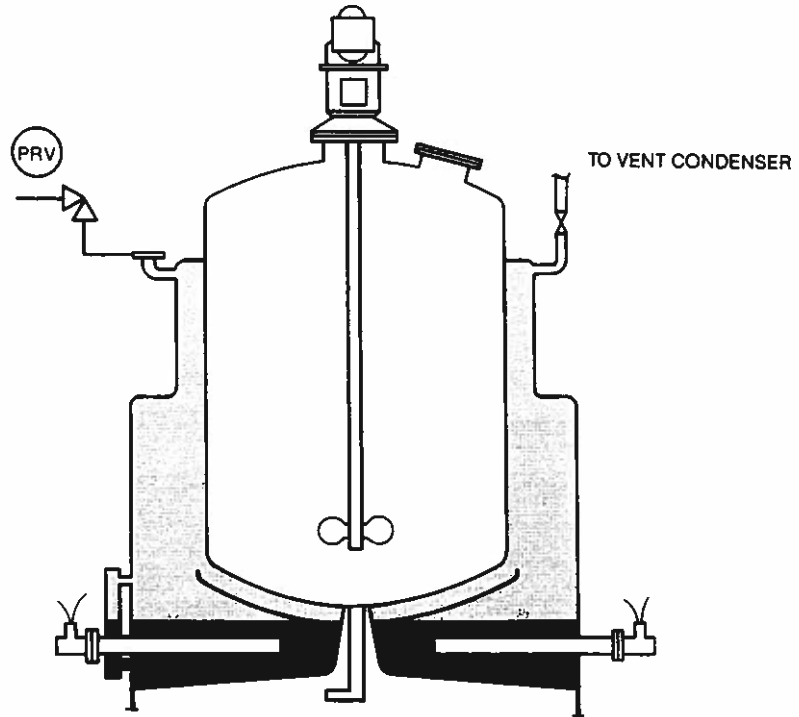

Figure 11—DOWTHERM Fluid Used for Alternate Vapor Phase Heating and Liquid Phase Cooling. Vaporizer is Natural Circulation Liquid-Tube Type.



**Figure 12—DOWTHERM Fluid Used
in Vapor Phase Integral
Vaporizer with Electric
Heat**



IV STARTUP AND OPERATING FACTORS

Cleaning of Systems

DOWTHERM heat transfer fluids are not corrosive and do not cause scaling of equipment. Consequently, special cleaning procedures are ordinarily not necessary.

When putting new vaporizers or heaters into service, it is generally necessary to remove oil, grease, or protective coatings which may have been applied during fabrication, construction, or storage. To do this, it is best to follow the equipment manufacturer's recommendations explicitly. Before any cleaning procedure, inspect the interior surfaces of the unit for any foreign materials. Any chemicals that may have been used in the cleaning procedure should be thoroughly removed.

The piping and other equipment in the system should be flushed with high pressure water, drained, and purged with air until dry before the initial charge of DOWTHERM fluid is added. In some cases it is desirable to use cleaning chemicals in water to aid in removing oily substances and scale. It is standard practice to install a screen ahead of pumps or any other moving equipment to catch foreign materials that may have been loosened during initial operation.

During use of vaporizers or heaters, carbon may form due to flame impingement, overfiring, or some other abnormal operating condition. If soft carbon forms, it can usually be removed by high pressure hot water. If hard carbon has formed, it generally can be removed by mechanical means or chemical cleaning.

Testing for Leakage

Water is generally used for hydrostatic testing of equipment for structural soundness. Leakage testing is carried out by introducing 50 psig of clean dry air. If there are no leaks, it should be possible to hold this pressure for 24 to 48 hours without pressure loss providing corrections are made for ambient temperature change. Any leaks which may be present can be located by testing joints, welds, stuffing boxes, etc., with a soapsuds and water solution applied with an ordinary paintbrush.

Flanges should not be insulated until the system is up to operating temperature. The bolts will require tightening.

Contamination and Degradation

Contamination. Contamination of DOWTHERM heat transfer media with the material being processed is probably the greatest source of difficulty.

Dow's experience indicates that about 75% of the failures in processing systems stem from such contamination.

Almost without exception, the materials processed in systems using DOWTHERM fluid have a lower thermal stability than the heat transfer medium. In general, they are organic materials which decompose leaving carbon deposits on the heating surfaces. Such carbon deposits result in overheating and may start local decomposition of the DOWTHERM fluid due to excessive film temperatures.

DOWTHERM heat transfer fluids are generally unreactive but under certain conditions will react with the material being heated. For example, in the presence of sulfuric acid or air, sulfonation or oxidation can occur.

Water can be rather dangerous in a system containing DOWTHERM fluid due to its extremely high vapor pressure at the normal operating temperature of the system. When water is present in a hot system, it causes a crackling noise when the temperature of the medium approaches the boiling point of the water. Due to the high vapor pressure of the water, it is easily vented off. Therefore, each time a vaporizer for DOWTHERM fluid is started, water and air should be removed. This can be accomplished by employing a vacuum or by heating and purging the system with vapors of the heat transfer medium.

Vent condensers and condensate collection tanks should be used. Condensate containing low boilers should not be returned to the heat transfer system.

Degradation. Purification of DOWTHERM heat transfer fluids presents no particular difficulties. The principal thermal degradation products are high-boiling compounds associated with low-boiling compounds. The high boilers are quite stable; however, if they build up in the fluid, the boiling point will rise. The low-boiling compounds usually collect in the high points of the system or expansion tank and are readily removed by venting. The high-boilers may be removed by distilling the heat transfer fluid. This should be done whenever the high-boilers build up between 10% and 15%.

Heat Transfer Fluid Quality

The quality of DOWTHERM heat transfer fluid can be determined by appropriate analytical methods. These include distillation, determination of pH and residues, ultraviolet and infrared spectroscopy, and gas or liquid chromatography.

Analysis and Fluid Credit Program

The Dow Chemical Company offers an analytical service for DOWTHERM fluids. It is recommended that users send a one-pint representative sample at least once each year to:

The Dow Chemical Company
Larkin Lab
1691 North Swede Road
Midland, Michigan 48674
Thermal Fluids Testing Lab

This analysis gives a profile of fluid changes to help identify trouble from product contamination or thermal decomposition.

When a sample is taken from a hot system, it should be cooled below 100°F before it is put into the shipping container. Cooling the sample below 100°F will prevent the possibility of thermal burns to personnel; also, the fluid is then below its flash point. In addition, any low boilers will not flash and be lost from the sample. Cooling can be done by either a batch or continuous process. The batch method consists of isolating the hot sample of fluid from the system in a properly designed sample collector and then cooling it to below 100°F. After it is cooled, it can be withdrawn from the sampling collector into a container for shipment.

The continuous method consists of controlling the fluid at a very low rate through a steel or stainless steel cooling coil so as to maintain it at 100°F or lower as it comes out of the end of the cooler into the sample collector. Before a sample is taken, the sampler should be thoroughly flushed. This initial fluid should be returned to the system or disposed of in a safe manner.

It is important that samples sent for analysis be representative of the charge in the unit. Ordinarily, samples should be taken from the (1) lower section of a natural circulation vaporizer, (2) circulating line of a forced circulation (pumped) vaporizer, or (3) main circulating line of a liquid system. Occasionally, additional samples may

have to be taken from different parts of the system where specific problems exist. A detailed method for analyzing the fluid to determine its quality is available upon request.

Used heat transfer medium which has been stored in drums or tanks should be sampled in such a fashion as to insure a representative sample.

For DOWTHERM A, DOWTHERM G and DOWTHERM J fluids, if analysis reveals significant thermal degradation of the medium, the customer will be advised to return the fluid in his system to Dow under the fluid credit program. If the fluid is contaminated with organic materials of low thermal stability, it may not be acceptable for Dow processing and will not qualify for the fluid credit program. In this case Dow will advise the customer that the fluid cannot be processed and therefore should not be returned to Dow. Fluid credit is not available for DOWTHERM HT and DOWTHERM LF. Fluid credit may be available for DOWTHERM Q fluid pending a detailed analysis.

No material should be returned to Dow until the fluid analysis has been completed and the customer informed of the results. If the analysis shows fluid changeout is necessary, the customer should order sufficient new material to recharge the system before sending the old fluid to Dow. Dow will credit the customer at the full purchase price for all usable material recovered, less a small processing charge based on the total quantity returned.

Before returning material for credit, contact the nearest sales office listed on the back of this bulletin for details.

It is possible to use a continuous reclamation process with DOWTHERM fluids. One manufacturer of continuous reclamation equipment is C.E. Sech Associates, Inc.

For further information, please contact your nearest Dow representative or call 1-800-447-4369 and ask for DOWTHERM fluids.

V ENGINEERING DATA AND CALCULATIONS

This section contains helpful information for maintenance personnel, operators, and engineers who are involved with problems of heat transfer or engineering in general. It includes some fundamentals of heat transfer, film coefficients of DOWTHERM fluids and pressure drops for DOWTHERM fluids in pipes. In addition, it discusses vaporization and nucleate boiling, including a procedure for determining the design characteristics of a reboiler. A detailed heat transfer discussion is not presented, but should be obtained from applicable texts and references.

Heat Transfer

Heat Transfer Mechanisms

Heat transfer is the science which deals with rates of exchange of heat between hot and cold bodies. There are three distinct ways in which heat may pass from a source to a receiver. These are convection, radiation, and conduction. The transfer of heat by convection proceeds mainly as the result of mixing. This type of heat transfer may be described by equation (1) where

$$Q = hA\Delta t \quad (1)$$

Conduction is the transfer of heat through solids, such as a fixed wall, or through quiet layers such as gases or liquids. This type of heat transfer is expressed in equation (2), and closely resembles the form of the convection equation.

$$Q = \frac{kA\Delta t}{L} \quad (2)$$

Radiation involves the transfer of radiant energy from a source to a receiver. Based on the second law of thermodynamics, it has been established that the rate at which a source radiates heat is:

$$Q = (0.173) (10^{-8}) (\epsilon) (F) (A) (T_1^4) - (T_2^4) \quad (3)$$

This is known as the fourth power law, in which T_1 is the absolute temperature, 0.173×10^{-8} is a dimensionless number known as the Stefan-Boltzmann constant, and ϵ is a factor peculiar to radiation and is called emissivity. The emissivity, like the thermal conductivity k , and the heat-transfer coefficient h , must be determined experimentally.

Process Heat Transfer

Process heat transfer deals with transfer rates as they occur in the equipment of the engineering and chemical process. The overall heat transfer coefficient must be determined in order to evaluate the heat transfer surface required. The overall heat transfer coefficient may be expressed by the following equation:

$$Q = UA\Delta t_{LM} \quad (4)$$

The overall heat transfer coefficient (U) is influenced by the fluid film heat transfer rates on each side of the tube (h_i and h_o), the resistance through the tube wall (r_w), and the fouling resistance due to deposits on both the inside and outside of the tube (r_i and r_o). In terms of these individual factors, the following equation can be written:

$$1/U = 1/h_i + 1/h_o + r_w + r_i + r_o \quad (5)$$

Nomenclature and Symbols

A	Heat Transfer Surface Area	ft ²
c_p	Specific Heat	Btu/(lb) (° F.)
d	Diameter	inch
D	Diameter	ft
f	Friction Factor	ft ² /in ²
F	View Factor	dimensionless
G	Mass Velocity	lb/(hr) (ft ²)
G'	Mass Velocity	lb/(sec) (ft ²)
h	Film Heat Transfer Coefficient	Btu/(hr) (ft ²) (° F.)
\bar{h}	Average Film Coefficient	Btu/(hr) (ft ²) (° F.)
k	Thermal Conductivity	Btu/(hr) (ft) (° F./ft)
k'	Thermal Conductivity	Btu.(hr) (ft ²) (° F./in)
L	Length and Thickness	ft
ln	Natural Logarithm — Base e	dimensionless
log	Common Logarithm — Base 10	dimensionless
m	Mass	lb
N	Number of baffles	dimensionless
n'	Number of tube passes	dimensionless
n	Revolutions per minute	dimensionless
Q	Heat Flow	Btu/hr
r	Fouling Resistance or Tube Resistance	(hr) (ft ²) (° F.)/Btu
s	Specific Gravity	dimensionless
t	Cold Fluid Temperature	° F.
T	Hot Fluid Temperature	° F.
T'	Absolute Temperature	° F.
U	Overall Coefficient of Heat Transfer	Btu/(hr) (ft ²) (° F.)
V	Fluid Velocity	ft/hr
v	Fluid Velocity	ft/sec
W	Mass Rate	lb/hr
W'	Condensation per Tube	lb/hr
Δ (delta)	Difference	
Δt	True or Effective Temperature Difference	° F.
Δt_L	Log Mean Temperature Difference (LMTD)	° F.
Δp	Pressure Difference	psi
ϵ (epsilon)	Emmissivity	dimensionless
λ (lambda)	Latent Heat	Btu/lb
μ (mu)	Viscosity $\mu = (\text{cps} \times 2.42)$	lb/(hr) (ft)
ρ (rho)	Density	lb/ft ³
σ (sigma)	Surface Tension	lb/ft

(For Subscripts see page 16.)

Subscripts:

- a average
- c clean
- d design
- e equivalent
- f film
- h helical
- i inside
- j jacket
- o outside
- s saturation
- t total
- v vapor
- w wall

$$R_e = \frac{DV\rho}{\mu} = \frac{DG}{\mu} \text{ Reynolds number, dimensionless}$$

The Controlling Film Coefficient

If one film coefficient is small and the other very large, the smaller coefficient provides the major resistance to heat flow. In this case, the overall coefficient of heat transfer for the equipment is very nearly the reciprocal of the major resistance, and is the controlling film coefficient.

The term r_w , the tube wall resistance, can be omitted in most cases. The exception to this is where both h_i and h_o are very high values and the dirt factors r_i and r_o are negligible.

Heat Flow Area

Inasmuch as a pipe has different areas per linear foot on its inside and outside surfaces, the film coefficients must be referred to the same heat flow area or they will not coincide per unit length. If the outside area A_o of the pipes is used, the h_i and r_i should be multiplied by A_i/A_o to give the value the coefficients would have if originally calculated on the basis of the larger outside area. Thus,

$$h_{io} = \frac{h_i A_i}{A_o} = \frac{d_i}{d_o} \tag{6}$$

Heat Transfer Rates, Clean and Dirty

The fouling factors (r_i, r_o) are the film coefficients which when added into the overall coefficient (U) represents the extra surface area built into the heat exchanger to maintain satisfactory operation without too frequent cleaning. With r_i and r_o equal to zero, U_c is the clean overall coefficient. The engineer is interested in the heat-transfer rate for the clean exchanger. It is customary to calculate this value first, then add on resistance for deposits to obtain the heat transfer rate when dirty (U_d). Utilizing the following equation,

$$\frac{1}{U_d} = \frac{1}{U_c} + r_i + r_o \tag{7}$$

figure 24 shown on page 36 will aid in obtaining U_d , the design overall heat-transfer coefficient.

Logarithmic Mean Temperature Difference

Given the heat duty (Q) and the overall design coefficient, (U_d) the remaining factor which must be

known in order to calculate the surface area required is the temperature difference between the two streams for the entire surface area.

Two fluids may transfer heat in concentric pipe equipment in either counterflow¹ or parallel flow² and the relative direction of the two fluids influences the value of the temperature difference.

When the temperature difference varies throughout the exchanger, a mean temperature difference must be found. When the fluids pass through an exchanger unchanged — liquids not vaporized and vapors not condensed — an overall Logarithmic Mean Difference (LMTD) is used.

$$LMTD = \Delta t_{LM} = \frac{\Delta t_1 - \Delta t_2}{\ln \frac{\Delta t_1}{\Delta t_2}} = \frac{\Delta t_1 - \Delta t_2}{2.3 \log \frac{\Delta t_1}{\Delta t_2}} \tag{8}$$

where:

Δt_1 = Maximum temperature difference

Δt_2 = Minimum temperature difference

Equation 8 is shown in Figure 13, page 17. Figures A and B show how Δt_1 and Δt_2 are determined.

Figure A — Counterflow

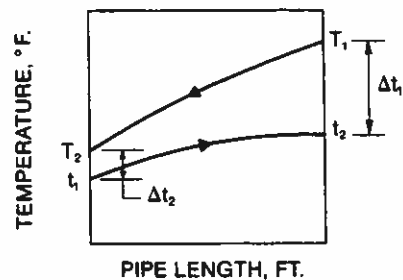

Figure B — Parallel Flow

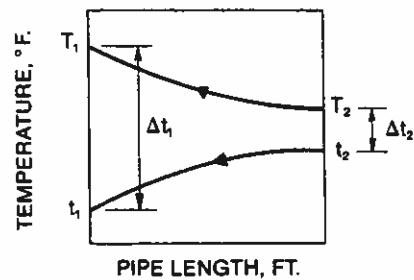
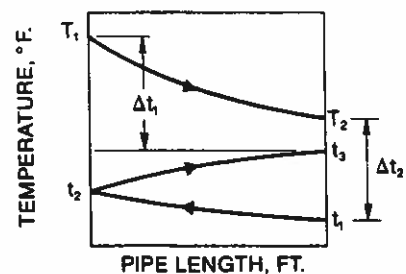

Figure C — Part Parallel — Part Countercurrent Flow



¹ Fluid on inside of pipe travels in opposite direction as fluid on outside of pipe.
² Fluid on inside and outside of pipe travel in same direction.

Figure 13 — Log Mean Temperature Difference

Log Mean Temperature Difference

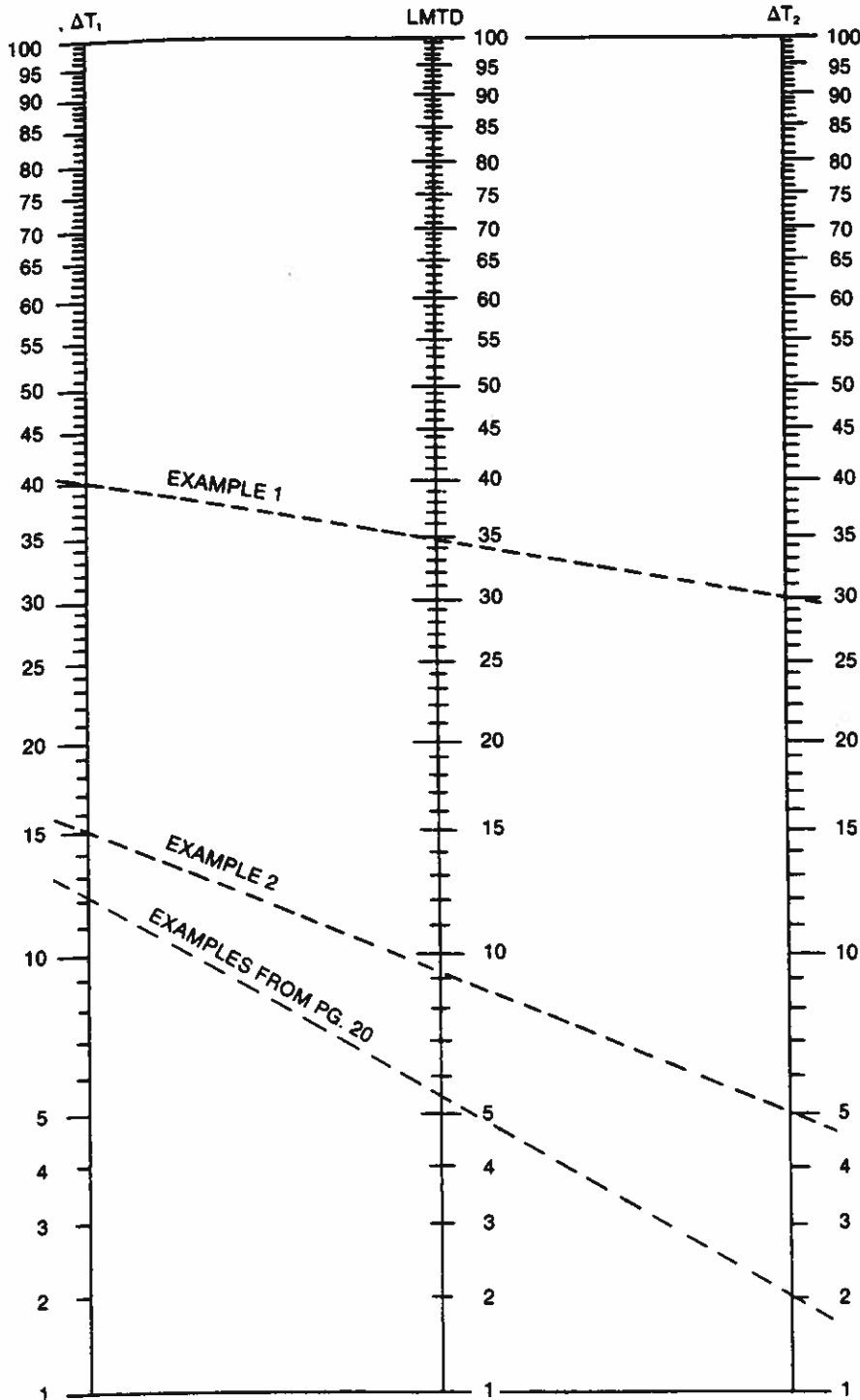

- EXAMPLES**
- (1) $T_1 = 120\text{ F.}, T_2 = 100\text{ F.}$
 $t_1 = 70\text{ F.}, t_2 = 80\text{ F.}$
 $\Delta T_1 = 120 - 80 = 40$
 $\Delta T_2 = 100 - 70 = 30$
 CONNECT ΔT_1 & ΔT_2 .
 LMTD = 34.5 F.
 - (2) $T_1 = 260\text{ F.}, T_2 = 140\text{ F.}$
 $t_1 = 90\text{ F.}, t_2 = 110\text{ F.}$
 $\Delta T_1 = 260 - 110 = 150\text{ (15)}$
 $\Delta T_2 = 140 - 90 = 50\text{ (5)}$
 CONNECT ΔT_1 & ΔT_2 .
 LMTD = 91 (9.1)

WHERE —

$$\begin{cases} \Delta T_1 = T_1 - t_2 \\ \Delta T_2 = T_2 - t_1 \end{cases}$$

$$\text{LMTD} = \frac{\Delta T_1 - \Delta T_2}{\ln \frac{\Delta T_1}{\Delta T_2}}$$

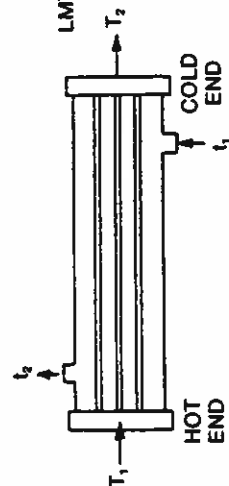

FOR EXPANSION OF SCALES, MULTIPLY OR DIVIDE ALL SCALES BY 10.

Boiling Film Coefficients

The heat transfer by vaporization (boiling) without mechanical agitation obviously is a combination of the ordinary liquid-free convection and the additional convection produced by the rising stream of bubbles.

When the temperature difference ($\Delta t = t_w - t_b$) between the wall of the tube and the boiling liquid is very small, the formation of the bubbles proceeds slowly, and the rate of the heat transfer is essentially that of free convection.

The typical boiling of fluids generally occurs in four consecutive regions as follows:

1. At low Δt (to approximately 10°F), (6°C.), the liquid is being superheated by natural convection and evaporation occurs only at the surface of the pool.
2. The next region is known as nucleate boiling region where vaporization takes place directly at the heating surface.
3. In the transition region from nucleate to film boiling a part of the surface is insulated with a vapor film.
4. In the film boiling region heat is transferred through the vapor film by conduction and radiation.

Of all these regions, the nucleate boiling region is technically most important because in this region it is possible to obtain the maximal heat transfer rate for any representative conditions.

Outside Coefficient on Coils in Vessel with Fluid Agitation. Chilton and co-workers¹ obtained a correlation for heat transfer from coils to fluid in a vessel with mechanical agitation. Their equation is as follows:

$$\frac{h_c D_j}{k} = 0.87 \left(\frac{60nL^2 \rho}{\mu} \right)^{0.62} \left(\frac{C_p \mu}{k} \right)^{1/3} \left(\frac{\mu}{\mu_w} \right)^{0.14}$$

This equation is represented by the upper line in Figure 14.

Vessel with Coils

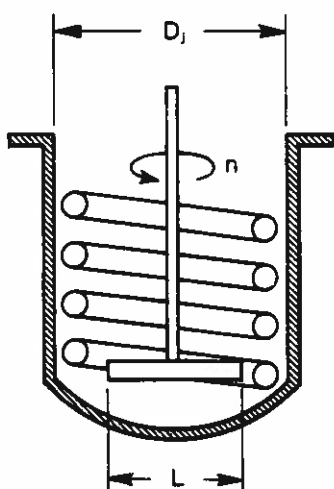

¹T. H. Chilton et al., *Ind. Eng. Chem.* 36, 510-16 (1944).

Jacketed Vessels with Fluid Agitation. Chilton and co-workers also found a correlation for heat transfer from liquid in a jacket to fluid in a vessel with mechanical agitation as follows:

$$\frac{h_j D_j}{k} = 0.36 \left(\frac{60nL^2 \rho}{\mu} \right)^{2/3} \left(\frac{C_p \mu}{k} \right)^{1/3} \left(\frac{\mu}{\mu_w} \right)^{0.14}$$

This equation is represented by the lower line in Figure 14.

Jacketed Vessels

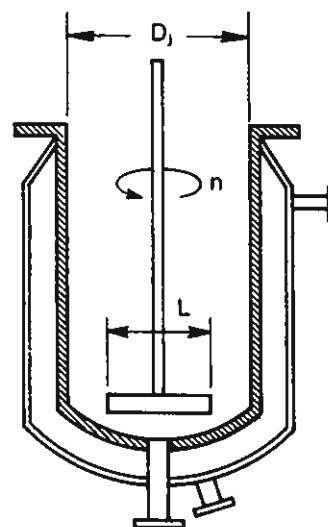

Surface Area Calculations

In order to illustrate the use of some of the charts and equations discussed, the following problem will be evaluated to determine the surface area required for a process heat exchanger.

Problem

It is desired to heat 9,000 lb./hr. of oil from 500°F (260°C) to 600°F (315.56°C). The oil is heat-sensitive and cannot be heated over 630°F (332.22°C). Condensing DOWTHERM A will be used at 620°F (326.67°C) in a horizontal tubular heat exchanger.

Assumptions:

1. The exchanger will have one shell pass and one tube pass.
2. DOWTHERM A will be on the shell side of the exchanger and no subcooling will take place.
3. The film coefficient, for the oil, $h_1 = 360 \text{ Btu}/(\text{hr.}) (\text{ft.}^2) (^\circ\text{F.})$.
4. The fouling factors will be; for the oil, $r_1 = 0.003 (\text{hr.}) (\text{ft.}^2) (^\circ\text{F.})/\text{Btu}$, for DOWTHERM A, $r_2 = 0.001 (\text{hr.}) (\text{ft.}^2) (^\circ\text{F.})/\text{Btu}$
5. Tubes in the exchanger will be $\frac{3}{4}$ " OD, 16 BWG steel.
6. Oil specific heat, $c = 0.40 \text{ Btu}/\text{lb.}^\circ\text{F.}$

Figure 14 — Heat Transfer Coefficients for Jackets and Coils with Fluid Agitation

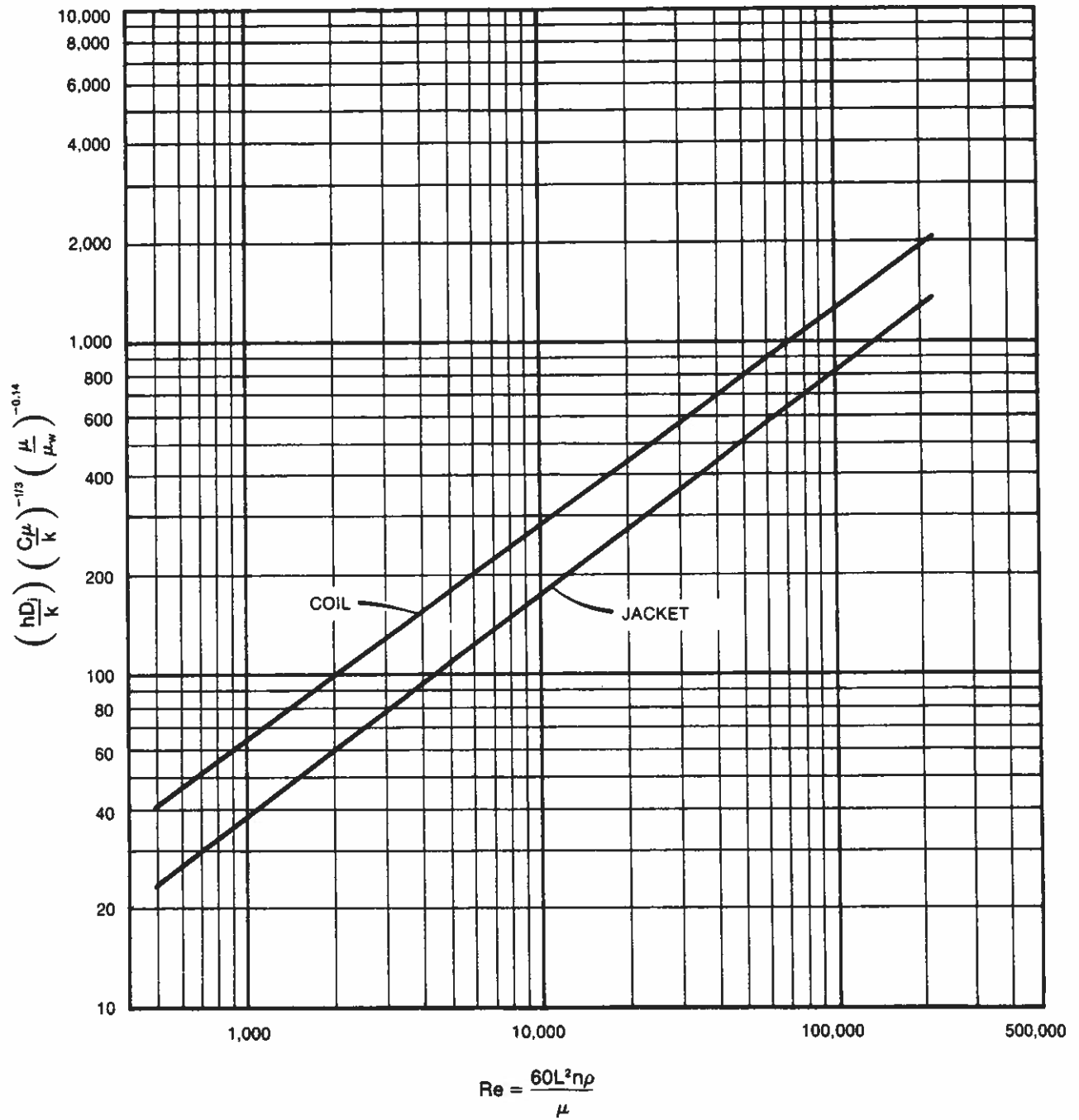

Solution:

1. Heat Balance

$$Q = mc_p \Delta t = (9,000) (0.4) (600-500) = 360,000 \text{ Btu/hr}$$

$Q = (W) (\lambda)$ or $W = Q/\lambda$
 $Q_{\text{DOWTHERM}} = Q_{\text{Oil}} = 360,000 \text{ Btu/hr}$
 $\lambda_{620^\circ\text{F.}} = 111.3 \text{ Btu/lb}$ (data from saturation properties table DOWTHERM A heat transfer medium bulletin)
 $W = 360,000/111.3 = 3235 \text{ lb/hr}$
 $g = \text{condensate flow} = 8.3 \text{ gal/min.}$ (Figure 15, page 21)

2. Log Mean Temperature Difference (LMTD)

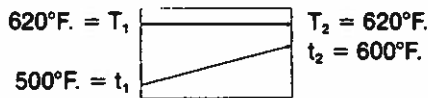

$$\text{LMTD} = \frac{\Delta t_1 - \Delta t_2}{2.3 \log \frac{\Delta t_1}{\Delta t_2}} \quad (\text{Equation 8})$$

$$\Delta t_1 = 620 - 500 = 120^\circ\text{F.}$$

$$\Delta t_2 = 620 - 600 = 20^\circ\text{F.}$$

$$\text{LMTD} = \frac{120 - 20}{2.3 \log_{10} (120/20)} = \frac{100}{(2.3) (0.778)} = 55.9^\circ\text{F.}$$

From Figure 13, page 17, LMTD = 56°

3. Clean Overall Heat Transfer Coefficient (U_c)

$$1/U = 1/h_i + 1/h_o + L/k + r_i + r_o \quad (\text{Equation 5})$$

To determine a clean overall heat transfer coefficient, let r_i , r_o and L/k equal zero. Thus.

$$\frac{1}{U_c} = \frac{1}{h_i} + \frac{1}{h_o}$$

A. Film coefficient on outside (h_o)

In order to calculate the outside film coefficient it is necessary to know the difference in temperature of the condensing vapor (T_v) and the pipe wall temperature (t_w). The pipe wall temperature is determined by trial and error calculations using the following equation.

$$t_w + t_a + \left(\frac{h_o}{h_i + h_o} \right) (T_v - t_a)$$

Process Heat Transfer by D. Q. Kern, McGraw-Hill, 1950, p. 97).

where t_w = wall temperature, °F.
 t_a = average temp. of cold fluid, °F.
 T_v = Temperature of vapor, °F.
 $t_a = (500 + 600)/2 = 550^\circ\text{F.}$
 $T_v = 620^\circ\text{F.}$

h_{io} ... Basing the coefficient on the outside area, h_i may be converted from inside to outside as follows

$$h_{io} = h_i \times \frac{D'_i}{D'_o} \quad (\text{Equation 6})$$

$$\frac{D'_i}{D'_o} = \frac{0.620}{0.750} = 0.827 \quad (\text{tube properties, Table A, page 38})$$

$h_i = 360 \text{ Btu/(hr) (ft}^2) (\text{°F.)}$ (given)
 $h_{io} = 360 \times 0.827 = 298 \text{ Btu/(hr) (ft}^2) (\text{°F.)}$
 To solve the above equation for t_w , assume $h_o = 150 \text{ Btu/(hr) (ft}^2) (\text{°F.)}$

$$\text{Thus, } t_w = 550 + \left(\frac{150}{150 + 298} \right) (620 - 550)$$

$$t_w = 550 + (0.335) (70) = 573^\circ\text{F.}$$

Now determine h_o from Figure 16, page 22) when $\Delta t = T_v - t_w = 620 - 573 = 47^\circ\text{F.}$

$D' = 0.750$ inches
 $(D') (\Delta t) = (0.750) (47) = 35.3$
 From graph, $h_o = 270 \text{ Btu/(hr) (ft}^2) (\text{°F.)}$

Since the assumed value does not agree with the calculated value, assume $h_o = 290$, and repeat calculations.

$$t_w = 550 + \frac{290}{290 + 298} (620 - 550)$$

$$t_w = 550 + (0.49) (70) = 584^\circ\text{F.}$$

and $\Delta t = T_v - t_w = 620 - 584 = 36^\circ\text{F.}$
 $(D') (\Delta t) = (36.0) (0.750) = 27.0$ and
 $h_o = 290 \text{ Btu/(hr) (ft}^2) (\text{°F.)}$

This is the design value for h_o as the assumed value equals the calculated value.

B. Clean Overall Heat Transfer Coefficient (U_c)

$$1/U_c = 1/h_{io} + 1/h_o$$

$$1/U_c = 1/298 + 1/290$$

$$1/U_c = 0.00336 + 0.00345 = 0.00681$$

$$U_c = 147 \text{ Btu/(hr) (ft}^2) (\text{°F.)}$$

Note: If the metal resistance (r_w) had been considered, it would equal 0.00024 (hr) (ft²) (°F.)/Btu (Table 8, page 38) and would have made $U_c = 142 \text{ Btu/(hr) (ft}^2) (\text{°F.)}$. The metal resistance is thus shown to be insignificant and may be neglected.

4. Design Overall Heat Transfer Coefficient (U_d)

$$\frac{1}{U_d} = \frac{1}{U_c} + r_{io} + r_o \quad (\text{Equation 7})$$

$$r_{io} = r_i \times \frac{d_i}{d_o} = 0.003 \times 0.827$$

$$r_{io} = 0.00248 \text{ (hr) (ft}^2) (\text{°F.)/Btu}$$

$$r_o = 0.001 \text{ (hr) (ft}^2) (\text{°F.)/Btu}$$
 (given)
 $1/U_c = 1/147 = 0.00681 \text{ (hr) (ft}^2) (\text{°F.)/Btu}$
 $1/U_d = 0.00681 + 0.00248 + 0.00100$
 $1/U_d = 0.01029 \text{ (hr) (ft}^2) (\text{°F.)/Btu}$
 $U_d = 97.2 \text{ Btu/(hr) (ft}^2) (\text{°F.)}$

or if read from Figure 24, page 36, we get

$$U_d = 97 \text{ Btu/(hr) (ft}^2) (\text{°F.)}$$

5. Surface Area

$$Q = U_d A \Delta t_{LM} \quad (\text{Equation 4})$$

$$A = Q/(U_d) (\Delta t_{LM}) = \frac{360,000}{(97.2) (55.9)} = 66.3 \text{ ft}^2$$

Figure 15— Condensate Flow vs. Heat Load DOWTHERM A Fluid

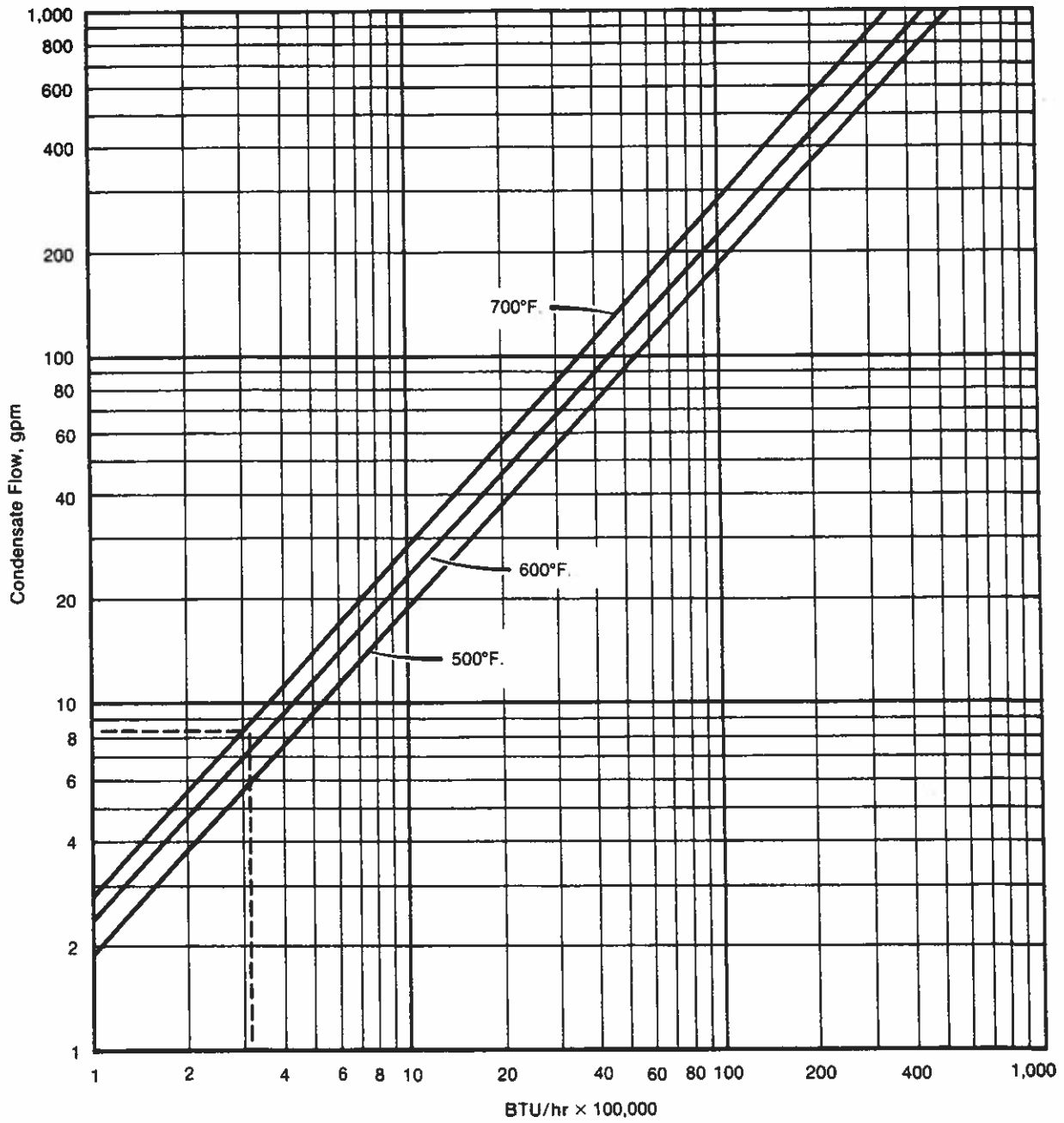

ASSUMES NO SUBCOOLING OF THE CONDENSATE

Figure 16 — Condensing Film Coefficient for DOWTHERM A Fluid
Outside Horizontal Pipes or Tubes

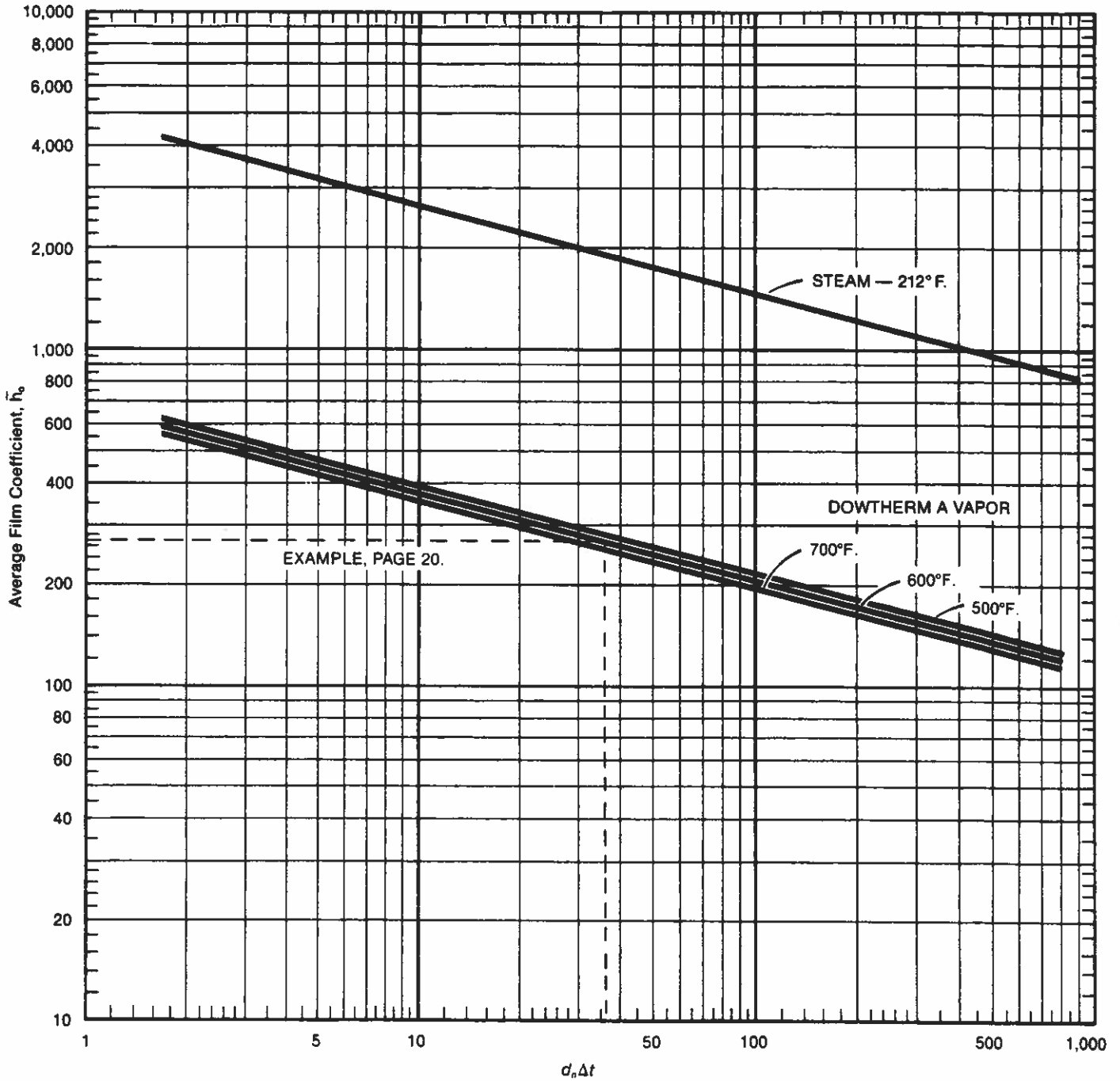

$$\bar{h}_o = 192.8 \left(\frac{k_f^3 \rho_f^2 \lambda}{\mu_f d_o \Delta t} \right)^{1/4}$$

Δt = Temperature Difference Between Vapor and Tube, °F.

NUSSELT EQUATION

¹Process Heat Transfer, D. Q. Kern, McGraw Hill, 1950, p.263.

Pressure Drop

When a fluid flows over a stationary or moving surface, the pressure of the fluid decreases along the length of the surface due to friction. This is commonly called the pressure drop of the system. Of particular interest are the pressure drops in pipes (tubes) and in heat exchanger shells.

The Sieder and Tate equation for the pressure drop in tubes is:

$$\Delta p = \frac{fG^2L n}{5.22(10)^{10}(D_i)(s)(\mu/\mu_w)^{0.14}}$$

Values of *f* vs. *Re* number are given in Figure 17.

The Sieder and Tate equation for the pressure drop in shells is:

$$\Delta p = \frac{fG^2D_i(N + 1)}{5.22(10)^{10}(D_e)(s)(\mu/\mu_w)^{0.14}}$$

Values of *f* vs. *Re* number are given in Figure 18.

In the design of all parts of a system, special consideration should be given to the large amount of flash vapor liberated on reduction of pressure. Because of the high ratio of specific heat to latent heat, much more flash vapor is liberated with DOWTHERM A than with steam. Consequently, all constrictions which would cause high pressure drops should be avoided.

Figure 17 — Tube-Side Friction Factors

$$\Delta P_t = \frac{f \times G_t^2 \times L \times n}{2 \times g \times \rho \times D \times \phi_t} = \frac{f \times G_t^2 \times L \times n}{5.22 \times 10^{10} \times D \times s \times \phi_t}, \text{ psi}$$

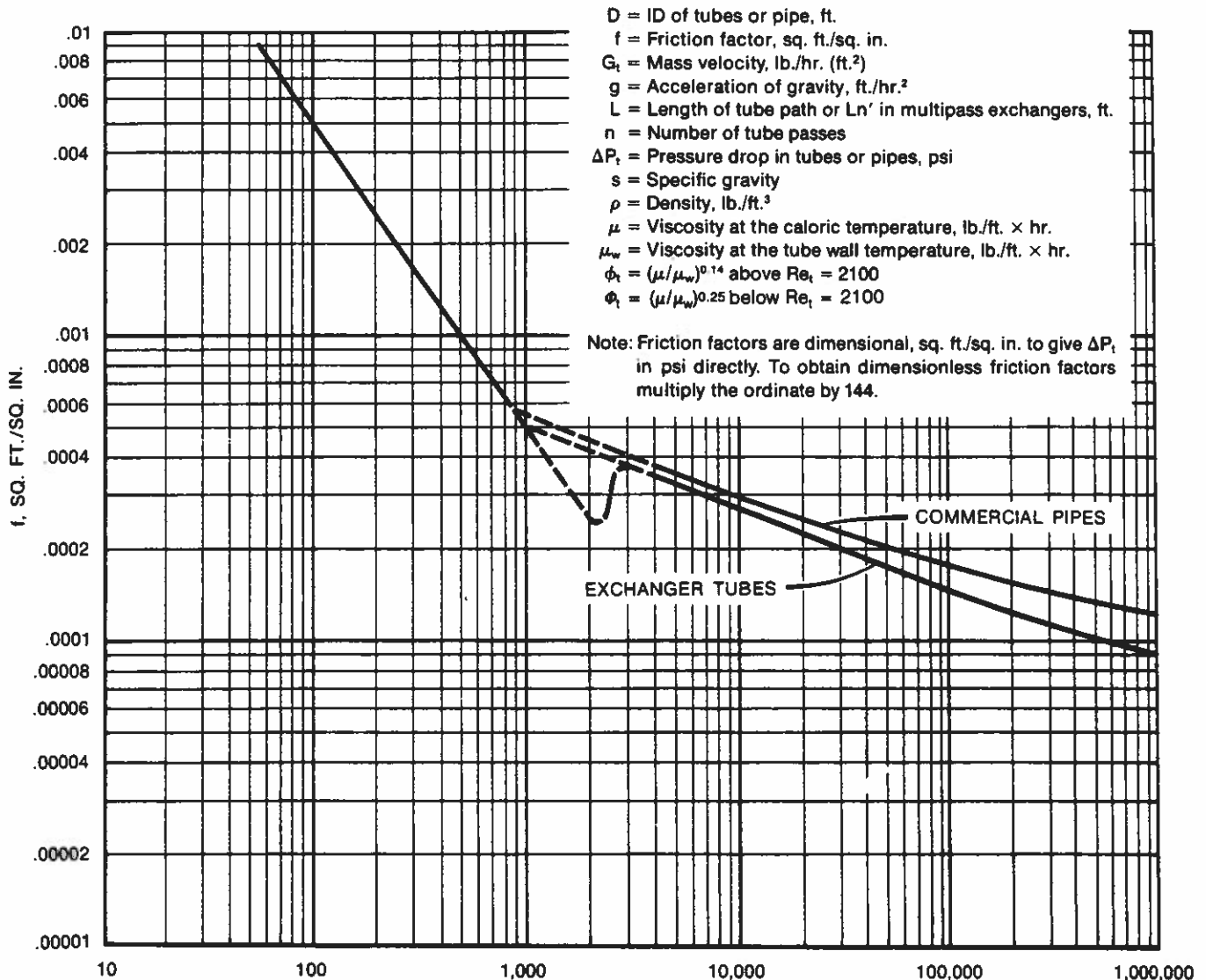

- D = ID of tubes or pipe, ft.
- f = Friction factor, sq. ft./sq. in.
- G_t = Mass velocity, lb./hr. (ft.²)
- g = Acceleration of gravity, ft./hr.²
- L = Length of tube path or Ln' in multipass exchangers, ft.
- n = Number of tube passes
- ΔP_t = Pressure drop in tubes or pipes, psi
- s = Specific gravity
- ρ = Density, lb./ft.³
- μ = Viscosity at the caloric temperature, lb./ft. × hr.
- μ_w = Viscosity at the tube wall temperature, lb./ft. × hr.
- φ_t = (μ/μ_w)^{0.14} above Re_t = 2100
- φ_t = (μ/μ_w)^{0.25} below Re_t = 2100

Note: Friction factors are dimensional, sq. ft./sq. in. to give ΔP_t in psi directly. To obtain dimensionless friction factors multiply the ordinate by 144.

Figure 18 — Shell-Side Friction Factors
For Bundles with 25% Cut Segmental Baffles.

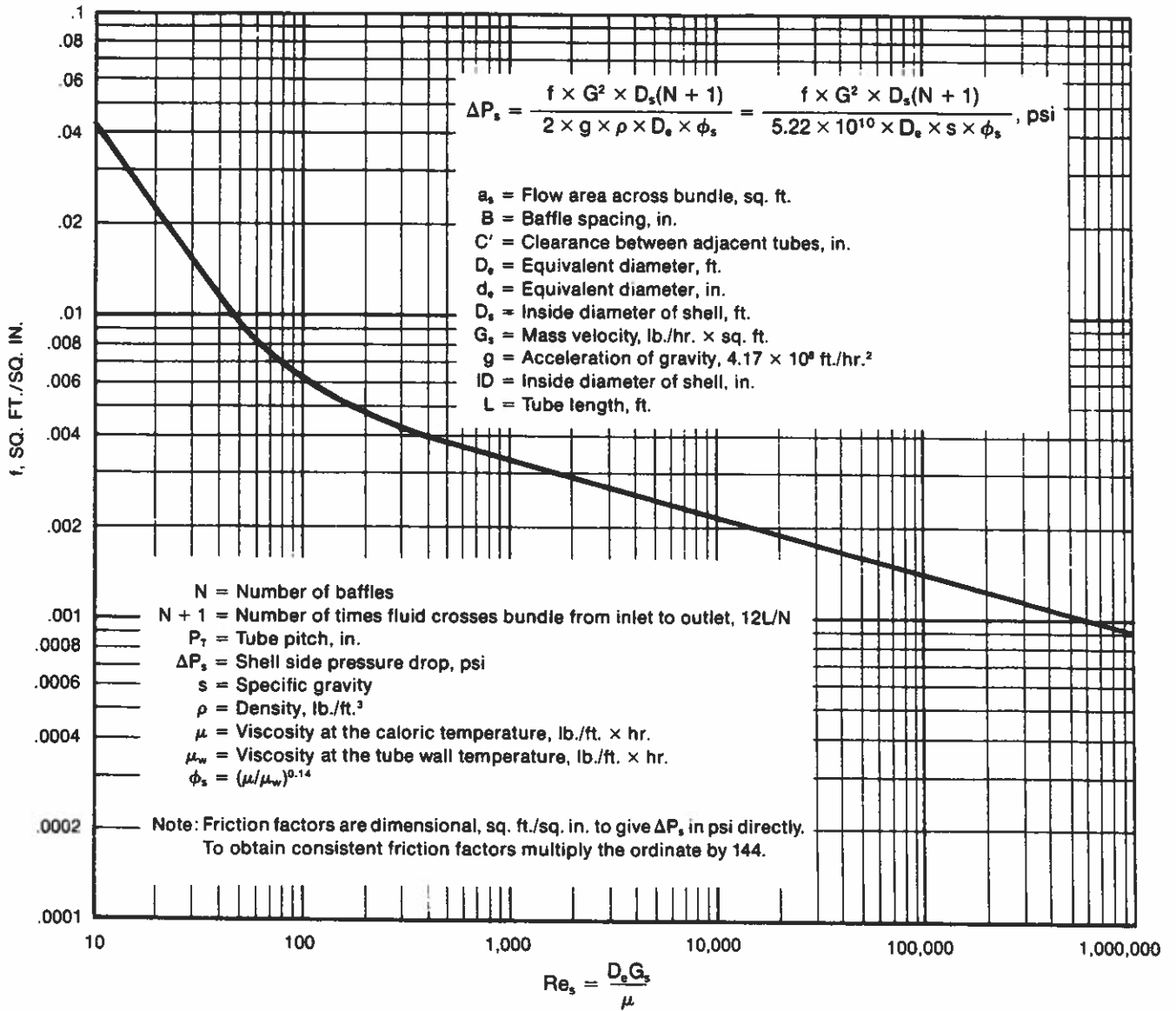

¹Process Heat Transfer, D. Q. Kern, McGraw Hill, 1950, p.839.

Vaporization and Nucleate Boiling

Several articles have been written about liquid phase heat transfer, but there is less published information concerning boiling or vaporization of organic heat transfer fluids. Recently, however, this subject has received more attention because of new developments that have improved heat transfer and reduced exchanger costs. This section reviews the general principles of vaporization and nucleate boiling. It describes forced and natural circulation vaporizers. A procedure is shown for rating a given horizontal kettle reboiler utilizing DOWTHERM A heat transfer fluid. Many of the concepts and procedures described are based on developments made by Heat Transfer Research Inc. (HTRI) of Alhambra, California.

General Principles of Vaporization and Nucleate Boiling

Nucleate boiling involves several stages of heating. During the first stage, convection currents are set up in the fluid, and its temperature rises until vaporization begins at the heating surface, causing incipient boiling. As heating continues, the temperature difference between the liquid and the heating surface becomes greater, and vaporization increases until superheating at the metal surface overcomes the surface tension of the liquid. At this point, bubbles form and nucleate boiling begins. As bubbles form and are detached from the metal surface, the liquid is agitated,

and new liquid contacts the surface. Continued heating increases the rate of bubble formation, thus increasing heat transfer and the nucleate boiling coefficient. Finally, the point of maximum nucleate boiling and maximum heat transfer is reached. Any further increases in heating surface temperature result in such a high rate of evaporation at the surface that nucleate boiling decreases and film boiling begins. The film boiling causes vapor blanketing and poor heat transfer. At extreme heating surface temperatures, nucleate boiling ceases and heat transfer reaches a minimum due to conduction through the film. With a further increase in temperature, there is an increase in heat transfer due to radiation and conduction.

The general relationship for heat flux and temperature drop through the film or liquid next to the heating surface is shown in Figure 19.

A uniform heat flux is necessary in order for the system to operate with maximum stability. The wider the variation in heat flux, the greater the chances of exposing the fluid to areas of excessively high temperature in fuel-fired vaporizers.

Ordinarily, nucleate boiling coefficients can be determined with an accuracy of $\pm 30\%$. Higher accuracy is possible if the investigator knows whether the heating surface is commercial grade, polished, or specially treated. Whenever possible, experimentally determined coefficients should be used.

Figure 19 — Heat Flux versus Temperature Drop through Liquid Film at Heating Surface

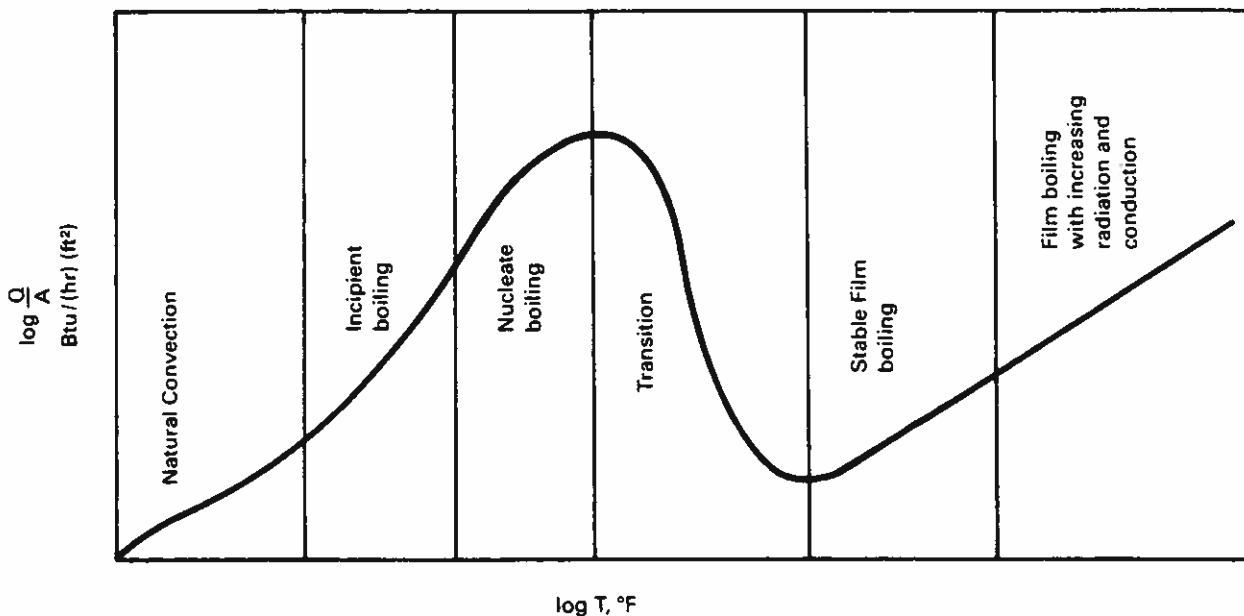

Types of Vaporizers

Vaporizers for DOWTHERM heat transfer fluid fall into two general categories — forced circulation and natural circulation units.

Forced circulation units utilize a pump to move the fluid through the vaporizer tube or tubes at high velocity. With such units, the velocity and heat transfer rates are so high that there is insufficient heat at the tube wall to produce nucleate boiling. Liquid is vaporized at the interface between the liquid film at the tube wall and the vapor core in the center of the tube. Vapor is separated from the liquid and goes to the user; liquid and condensate are returned to the vaporizer.

Natural circulation units utilize the difference in the density of the liquid and the generated vapor to promote circulation of the fluid. Units are of two general types — horizontal, which include kettle reboiler, fire tube, and electric types, and vertical, which include fire tube and thermosiphon units. Vapor may be produced either through vaporization or nucleate boiling.

With natural circulation units, vaporization can occur either inside or outside the tubes. Vaporizing inside of vertical tubes differs from vaporizing outside of vertical and horizontal tubes in that at very high heat fluxes certain limitations to heat transfer are possible. Due to the smaller flow area for the generated vapor, hydrodynamic effects can become important. Three types of limitations to heat flux are: 1) choke flow, 2) film boiling, and 3) mist flow. The heat fluxes that can cause

these conditions are much higher than those used to design vaporizers for DOWTHERM; therefore, these limitations are not usually a problem.

The following section describes the procedure for rating a given horizontal kettle reboiler. This type unit was chosen as an example because of its wide industrial use and also because it illustrates the use of liquid medium to generate vapors of the same medium. The advantages of this design include (1) uniform heating of the product, (2) elimination of the high tube surface temperatures that are possible with direct-heated vaporizers, and (3) elimination of product contamination of the primary heat loop.

At this point, a few general comments concerning bundle design are in order. Tube diameter and layout have very little effect on overall exchanger capacity. Increasing tube spacing increases bundle maximum heat flux but decreases the boiling heat transfer coefficient somewhat. Large diameter bundles or bundles with tight tube spacing tend to limit the heat flux due to poor circulation and vapor blanketing of the inner and upper tubes.

If a small temperature difference between the fluids is desired, close tube spacing can be used. For high temperature difference (limited only by maximum heat flux) wider tube spacing should be used. For a high design heat flux, a larger shell may be required to prevent entrainment.

In general, bundles should have as small a diameter as structural limitations on length will permit.

VI DETERMINING DESIGN CHARACTERISTICS OF REBOILER

The design values herein determined include the vapor capacity, liquid flow rate, and temperature difference between the inlet and the outlet, overall heat transfer coefficient (clean), average temperature drop through each film and the metal tube, vapor temperature, and average film temperature for a natural circulation vaporizer. The particular unit under discussion is a U-tube horizontal kettle reboiler utilizing DOWTHERM A heat transfer fluid inside the tubes to vaporize DOWTHERM A fluid outside the tubes. Fluid is pumped through the tubes while natural circulation occurs outside the tubes (shell side). This system is illustrated in Figure 21.

Figure 21 — Horizontal Kettle Reboiler

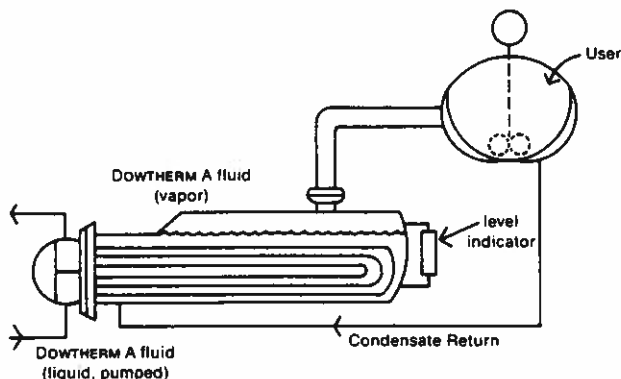

The safe maximum heat fluxes for units of this type range from 30,000-60,000 Btu/hr/ft² for most industrial uses. Maximum design heat flux is a function of fluid properties, system pressure, and bundle geometry.

The first step in the procedure consists of determining the maximum heat fluxes that will produce nucleate boiling at 500° F, 600° F, and 700° F for a single tube.

The maximum heat flux is determined from Mostinski's equation.[†]

$$\frac{Q_{\max}}{P_c} = 803 \left(\frac{P}{P_c} \right)^{0.35} \left[1 - \left(\frac{P}{P_c} \right) \right]^{0.9}$$

Where: Q_{\max} = maximum heat flux, Btu/hr/ft²
 P_c = Critical pressure, psia
 P = operating pressure, psia

[†]See *Teplotnergetika*, Vol 4, 1963, 66. Eng. Abst. *Brit Chem. Eng.*, Vol 8, No. 8, 1963, 580.

For example, for DOWTHERM A at 600° F

$$\frac{Q_{\max}}{455} = 803 \left(\frac{45.34}{455} \right)^{0.35} \left[1 - \frac{45.34}{455} \right]^{0.9}$$

The results are shown in Table 2.

Table 2 — Maximum Heat Flux for Single Tube

Temp., °F	$\left(\frac{Q}{A} \right)$ Max Btu/hr/ft ²
500	110,000
600	149,000
700	173,000

Bundle Maximum Heat Flux Calculation

The single-tube maximum heat flux was not used for rating the kettle reboiler directly. However, it does provide insight as to the upper flux limits that can be obtained at various temperatures in nucleate boiling. HTRI has developed improved correlations that do use the single-tube upper limit in determining maximum bundle flux. Since that information is confidential to HTRI members, the calculations presented below were made using equations published in the open literature. The results obtained herein are close to (slightly more conservative than) HTRI's present recommendations and are suitable for engineering purposes.

The tube bundle of the reboiler contains 312 tube holes (two per tube) and a pitch ratio of 1.33. The tube bundle is 3.7 feet long with two tube passes. The tubes are 14 BWG wall thickness steel, have an outside diameter (d_o) of 0.75 inch, an inside diameter (d_i) of 0.584 inch, and the ratio of the outside to the inside diameter ($R_{o/i}$) is 1.285. The total outside surface area is 229 square feet.

The bundle maximum heat flux at 500° F, 600° F, and 700° F was determined from the work of Palen and Small,^{††} using the following equation.

$$\left(\frac{Q}{A} \right)_{\max} = 61.6 \frac{P}{D_o \sqrt{N}} \rho v \lambda \left[\frac{g \sigma (\rho \ell - \rho v)}{\rho v^2} \right]^{1/4}$$

Where

- $\frac{Q}{A}$ max = bundle maximum heat flux, BTU/hr/ft²
 P = tube pitch, feet
 D_o = outside diameter of tube, feet, (d_o in inches)
 D_i = inside diameter of tube, feet, (d_i in inches)
 N = number of tubes (or tube holes for "U" tube bundle)
 ρv = density vapor, lbs./ft³
 $\rho \ell$ = density liquid, lbs./ft³
 λ = heat of vaporization, Btu/lb
 σ = surface tension, lb/ft
 g = gravitational constant, 4.18×10^8 ft/hr²
 $R_{o/i} = \frac{d_o}{d_i}$

^{††}See *Hydrocarbon Processing* magazine, Vol. 43, No. 11, Nov., 1964, 199-208.

Example at 600° F

$$\left(\frac{Q}{A}\right)_{\max} = 61.6 \frac{1.33/12}{0.75/12\sqrt{312}} (0.7237) (114.1)$$

$$\left(\frac{Q}{A}\right)_{\max} = 39,000 \text{ Btu/hr/ft}^2$$

$$\left[\frac{4.18 \times 10^8 (8.9 \times 10^{-4}) (49.29 - 0.7237)}{0.7237^2} \right]$$

The bundle maximum heat fluxes are tabulated below.

Temperature, °F	$\left(\frac{Q}{A}\right)_{\max}$ Btu/hr/ft ²
500	29,000
600	39,000
700	44,000

Maximum heat flux for a bundle is considerably less than for a single tube. This is due primarily to the flow resistance the liquid must overcome in order to reach the inner tubes in the bundle to replenish the boiling process.

The surface tension for DOWTHERM A fluid was determined from the following equation (for non-polar fluids) from Reid and Sherwood, 2nd Edition, 1966, equations 8 and 9.

$$\frac{\sigma_1}{\sigma_2} = \frac{1 - \frac{t_1}{t_c}}{1 - \frac{t_2}{t_c}}$$

Where σ_1 = known surface tension, dynes/cm
 σ_2 = unknown surface tension, dynes/cm
 t_1 = absolute temperature at σ_1 , °R
 t_2 = absolute temperature at σ_2 , °R
 t_c is the critical temperature, °R

For this calculation $\sigma_1 = 40.1 \frac{\text{dynes}}{\text{cm}}$,

$t_1 = 528^\circ \text{R}$, $t_c = 1387^\circ \text{R}$

Temperature	Calculated σ dynes/cm	σ lb/ft
500	17.4	11.9×10^{-4}
600	13.0	8.9×10^{-4}
700	8.1	5.5×10^{-4}

Vaporizing Film Coefficients

Three heat fluxes below the above-determined maximum bundle heat fluxes were assumed based on present industrial practice. Then film coefficients were calculated at 500° F, 600° F and 700°, using the Mostinski equation.

The average vaporizing (boiling) heat transfer film coefficient for tube bundles increases with pressure (temperature) and is usually higher than the nucleate

boiling coefficient for a single tube. This is presumably due to enhancement by convection caused by the vigorous agitation of two-phase flow. No data has been published for tube bundle boiling coefficients, so the more conservative single tube approach was used. The single-tube nucleate boiling coefficient was determined from the following equation from Mostinski:

$$h = .00658 (P_c)^{0.69} \left(\frac{Q}{A}\right)^{0.7} \left[1.8 \left(\frac{P}{P_c}\right)^{0.17} + 4 \left(\frac{P}{P_c}\right)^{1.2} + 10 \left(\frac{P}{P_c}\right)^{10} \right]$$

Where h = vaporizing film coefficients,
 Btu/hr/ft²/°F

P_c = critical pressure, psia

$\frac{Q}{A}$ = operating heat flux, Btu/ht/ft²

P = operating pressure, psia

Example: at 600°F and $\frac{Q}{A} = 20,000$

$$h = .00658 (455)^{0.69} (20,000)^{0.7} \left[1.8 \left(\frac{45.34}{455}\right)^{0.17} + 4 \left(\frac{45.34}{455}\right)^{1.2} + 10 \left(\frac{45.34}{455}\right)^{10} \right]$$

$$h = 677 \text{ Btu/hr/ft}^2/\text{°F}$$

Figure 22 — ΔT versus Heat Flux. (Plot of table 3)

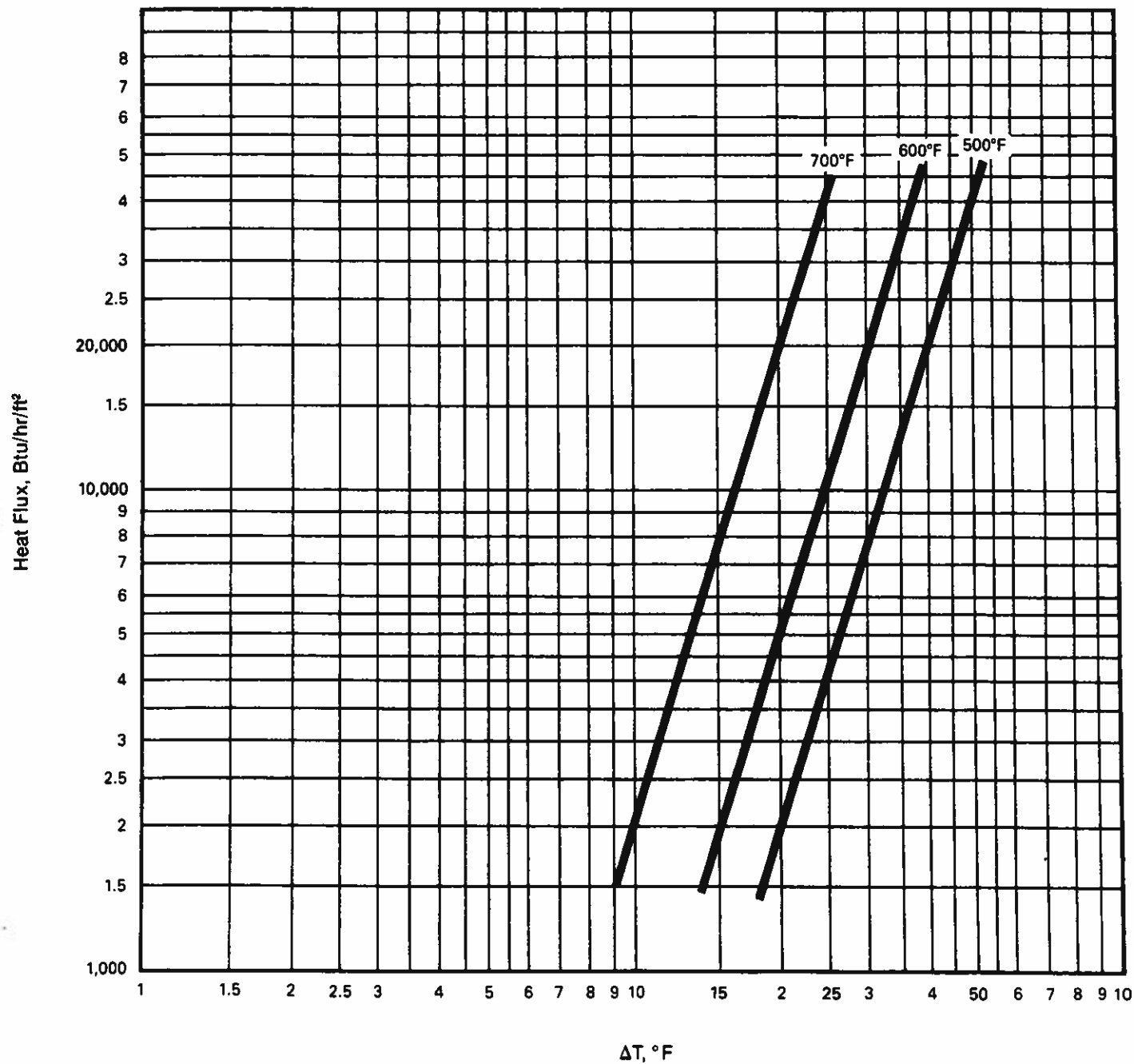

Film Temperature Drop

Temperature drop through the vaporizing film was calculated by dividing the three assumed heat fluxes by the film coefficient. For example, at a bundle heat flux of 20,000 Btu/hr/ft² and 600°F, calculations show that the vaporizing film coefficient is 677 Btu/hr/ft²/°F.

$$\text{From } \frac{Q}{A} = h\Delta T$$

$$\Delta T = \frac{Q}{Ah} = \frac{20,000}{677} = 29.54^\circ\text{C (say } 30^\circ\text{F)}$$

Three bulk temperatures were selected to show the effect of a varying heat flux on the film coefficient and ΔT through the vaporizing film. Table 3 and Figure 22 show the results.

These results clearly show that a higher temperature gives a larger film coefficient and a lower ΔT at the same heat flux. Greater vapor density along with lower viscosity, latent heat, liquid density, and surface tension are the major factors contributing to the higher film coefficients. It is interesting to note that a relatively large increase in heat flux may be obtained with a small increase in temperature through the film.

Example Problem for Rating a Reboiler

These calculations were utilized for rating the reboiler to produce vapor at 600°F at a heat flux of 20,000 Btu/hr/ft². Trial-and-error calculations showed that a liquid inlet temperature of 700°F and an outlet temperature of 670°F were required to generate vapor at 600°F. The Log mean ΔT is:

1.

$$\Delta T_{LM} = \frac{\Delta T_1 - \Delta T_2}{2.3 \log \frac{\Delta T_1}{\Delta T_2}} = \frac{(700 - 600) - (670 - 600)}{2.3 \log \frac{100}{70}}$$

$$\Delta T_{LM} = \frac{30}{2.3(0.154)} = 85^\circ\text{F}$$

2. To determine the liquid flow rate, the heat flow of the unit was first calculated by multiplying the number of square feet by the assumed heat flux of 20,000 (below-maximum bundle heat flux.)

$$Q = (229)(20,000) = 4,500,800 \text{ Btu/hr.}$$

Next, mass flow rate was determined.

$$W = \frac{Q}{C_p \Delta T_{\text{fluid}}} = \frac{4,580,000}{(.606)(700 - 670)} = 252,000 \text{ lbs/hr liquid}$$

This information was then used to determine the liquid flow rate per tube as shown below.

$$V_t = \frac{W}{3600 N_t \rho_L A}$$

Where

W = liquid flow rate, lbs/hr.

A = Cross-sectional area of tube, ft²

N_t = number of tubes = $\frac{312}{2} = 156$

ρ_L = density of medium, lb/ft³

V_t = velocity, ft/sec.

$$V_t = \frac{252,000}{3600(156)(45.7)(0.00186)} = 5.28 \text{ ft/sec}$$

3. The liquid film correlation used for this example is good only for turbulent flow. Therefore, to show that the flow of medium through the tubes is turbulent, the Reynolds Number (R_e) was determined.

$$R_e = \frac{D V_t \rho_L}{\mu}$$

Where

$$D = \frac{D_i}{12} = \frac{0.584}{12} = 0.0487 \text{ feet}$$

$$\mu = 0.16 \text{ cps} \times 0.000672 \text{ lb/sec/ft} = 0.00010752$$

$$R_e = \frac{0.0487(5.28)(45.7)}{0.00010752} = 109,000 \text{ (turbulent)}$$

Table 3 — Film Coefficients and ΔT 's at Heat Fluxes Below Maximum Bundle Heat Fluxes

Temp. °F	Heat Flux BTU/hr/ft ²	Film Coefficient h BTU/hr/ft ² /°F	Temperature Drop ΔT film °F
500	5,000	189	26
	10,000	309	33
	20,000	500	40
600	5,000	256	20
	10,000	418	24
	20,000	677	30
700	5,000	374	13
	10,000	611	16
	20,000	988	20

4. The heat transfer coefficient for liquid from the inside to the outside of the tubing (h_{io}) was next determined. A correlating parameter (X-AXIS) was first calculated for the relation shown below.

$$D_i v \rho_L = (0.584) (5.28) (45.7) = 141$$

The point on the horizontal scale of Figure 23 that corresponded to the correlating parameter was located and a vertical line drawn to intersect the 685°F represents the average for the liquid inlet temperature (700°F) and the liquid outlet temperature (670°F) calculated earlier. From the point of intersection, a horizontal line was drawn to the vertical scale to find the h_{io} of 310.

Dividing the h_{io} by the inside diameter of the tube gave the heat transfer coefficient for the inside of the tube, which was then used to find the desired h_i .

$$h_i = \frac{310}{0.584} = 531$$

$$h_{io} = \frac{h_i}{R_{of}} = \frac{531}{1.285} = 413$$

5. The overall U_o (clean) was then determined

$$\frac{1}{U_o} = \frac{1}{h_{io}} + \frac{1}{h_o} + rw$$

Where U_o = Overall heat transfer coefficient, based on outside tube surface area.

rw = factor calculated from thermal conductivity and tubing data, table 8 page 39. = .0003

$$h_{io} = 413$$

h_o = vapor film coefficient of unit at 600°F and 20,000 Btu heat flux (see table 3, page 30) = 677

$$\frac{1}{U_o} = \frac{1}{413} + \frac{1}{677} + \frac{0.007817}{25}$$

$$\frac{1}{U_o} = 0.00242 + 0.00148 + 0.0003 = 0.00420$$

$$U_o = \frac{1}{0.00420} = 238 \text{ Btu/ht/ft}^2/\text{°F}$$

8. The foregoing values were then used to calculate the average temperature drop through each film and the metal tube as follows

$$\Delta T_{\text{vapor film}} = (685 - 600) \frac{\frac{1}{h_o}}{\frac{1}{U_o}} = (85) \frac{(.00148)}{.00420} = 30^\circ\text{F}$$

$$\Delta T_{\text{tube wall}} = (685 - 600) \frac{rw}{\frac{1}{U_o}} = (85) \frac{0.0003}{0.00420} = 6.0^\circ\text{F}$$

$$\Delta T_{\text{liquid film}} = (685 - 600) \frac{\frac{1}{h_{io}}}{\frac{1}{U_o}} = (85) \frac{(0.00242)}{0.00420} = 49^\circ\text{F}$$

$$\text{Total } \Delta T_{LM} = 85.0^\circ\text{F}$$

7. From the temperature drop through the two films, average film temperatures were then determined.

$$\text{Average vapor film temperature} = 600 + \frac{30}{2} = 615^\circ\text{F}$$

$$\text{Average liquid film temperature} = 685 - \frac{49}{2} = 660^\circ\text{F}$$

The film coefficients calculated at these average film temperatures will not differ greatly from those previously calculated at 600°F and 685°F to warrant another determination.

As a final check on the validity of the foregoing procedure, the heat flux for the unit was determined using the values for U_o and the log mean temperature drop calculated previously.

$$\frac{Q}{A} = U_o \Delta T_{LM} = 238 (85^\circ\text{F}) = 20,200$$

This value agrees well with the originally assumed flux of 20,000 Btu/hr/ft².

8. To summarize, the unit has a vapor capacity of 4,580,000 Btu/hr at 600°F, a total mass flow rate of 252,000 lb/hr (5.28 ft/sec/tube) liquid at a temperature drop of 700°F to 670°F, an overall U_o (clean) of 238 Btu/hr/ft²/°F, average temperature drops through the vapor film, tube wall, and liquid film of 30°F, 6.0°F and 49°F, respectively, and average vapor film and liquid film temperatures of 615°F and 660°F, respectively. These calculations assume no heat loss. The unit could be rated for higher or lower temperatures at different heat fluxes. Fouling factors could also be applied. In any case, process requirements dictate the design criteria and operational range of a given unit. Of course, a unit can be sized for a specific duty and temperature.

**Figure 23 — Liquid Film Coefficient
For DOWTHERM A Fluid Inside Pipes and Tubes
(Turbulent Flow Only)**

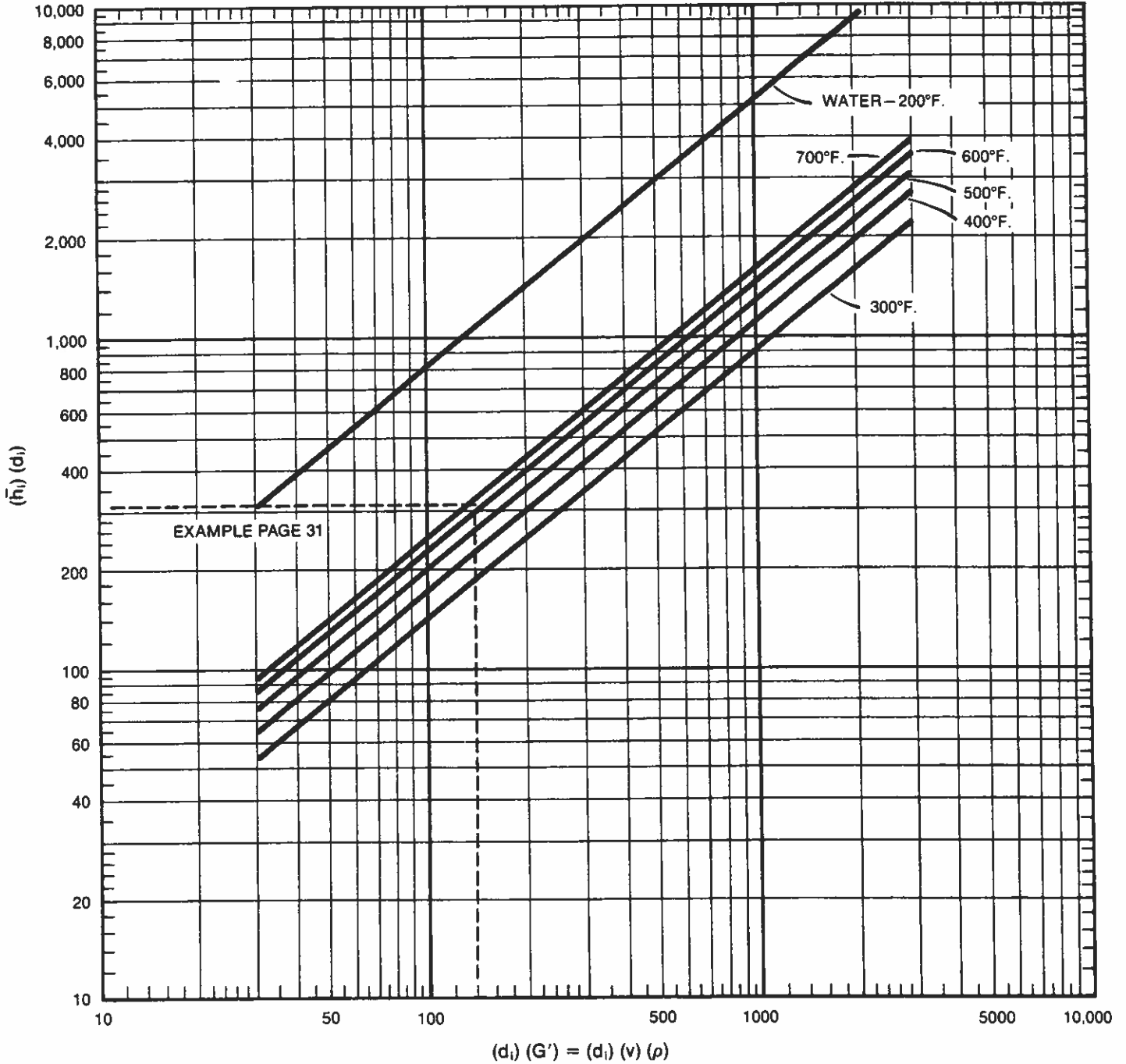

$$\frac{\bar{h}_i d_i}{k} = 31.06 \left(\frac{d_i G'}{\mu} \right)^{-0.8} \left(\frac{C_p \mu}{k} \right)^{1/3} \left(\frac{\mu}{\mu_w} \right)^{-0.14}$$

Chart Based on $\left(\frac{\mu}{\mu_w} \right)^{-0.14} = 1$

VII GENERAL TECHNICAL DATA

Table 4 — Steel Pipe Dimension — Capacities and Weights*

Nominal Pipe Size, in.	Outside Diam., in.	Schedule No.	Wall Thickness, in.	Inside Diam., in.	Cross-Sectional Area Metal, sq. in.	Inside Sectional Area, sq. ft.	Circumference, ft., or Surface sq. ft. per ft. of Length		Capacity at 1 ft. Per Sec. Velocity		Weight of Pipe Per Ft., Lb.
							Outside	Inside	U. S. Gal. Per Min.	Lb. Per Hr. Water	
1/8	0.405	40	0.088	0.269	0.072	0.00040	0.106	0.075	0.179	89.5	0.25
		80	.095	.215	.093	.00025	.106	.0563	.112	56.0	.32
1/4	0.540	40	.088	.364	.125	.00072	.141	.0954	.323	161.5	.43
		80	.119	.302	.157	.00050	.141	.0792	.224	112.0	.54
3/8	0.675	40	.091	.493	.167	.00133	.177	.1293	.596	298.0	.57
		80	.126	.423	.217	.00098	.177	.1110	.440	220.0	.74
1/2	0.840	40	.109	.622	.250	.00211	.220	.1630	.945	472.5	.85
		80	.147	.546	.320	.00163	.220	.1430	.730	365.0	1.09
		160	.187	.466	.384	.00118	.220	.1220	.529	264.5	1.31
3/4	1.050	40	.113	.824	.333	.00371	.275	.2158	1.665	832.5	1.13
		80	.154	.742	.433	.00300	.275	.1942	1.345	672.5	1.48
		160	.218	.614	.570	.00206	.275	.1610	0.924	462.0	1.94
1	1.315	40	.133	1.049	.494	.00600	.344	.2745	2.690	1,345.0	1.68
		80	.179	0.957	.639	.00499	.344	.2505	2.240	1,120.0	2.17
		160	.250	0.815	.837	.00362	.344	.2135	1.625	812.5	2.85
1 1/4	1.660	40	.140	1.380	.669	.01040	.435	.362	4.57	2,285.0	2.28
		80	.191	1.278	.881	.00891	.435	.335	3.99	1,995.0	3.00
		160	.250	1.160	1.107	.00734	.435	.304	3.29	1,645.0	3.77
1 1/2	1.900	40	.145	1.610	0.799	.01414	.498	.422	6.34	3,170.0	2.72
		80	.200	1.500	1.068	.01225	.498	.393	5.49	2,745.0	3.64
		160	.281	1.338	1.429	.00976	.498	.350	4.38	2,190.0	4.86
2	2.375	40	.154	2.067	1.075	.02330	.622	.542	10.45	5,225.0	3.66
		80	.218	1.939	1.477	.02050	.622	.508	9.20	4,600.0	5.03
		160	.343	1.689	2.190	.01556	.622	.442	6.97	3,485.0	7.45
2 1/2	2.875	40	.203	2.469	1.704	.03322	.753	.647	14.92	7,460.0	5.80
		80	.276	2.323	2.254	.02942	.753	.609	13.20	6,600.0	7.67
		160	.375	2.125	2.945	.02463	.753	.557	11.07	5,535.0	10.0
3	3.500	40	.216	3.068	2.228	.05130	.917	.804	23.00	11,500.0	7.58
		80	.300	2.900	3.016	.04587	.917	.760	20.55	10,275.0	10.3
		160	.437	2.626	4.205	.03761	.917	.688	16.90	8,450.0	14.3
3 1/2	4.000	40	.226	3.548	2.680	.06870	1.047	.930	30.80	15,400.0	9.11
		80	.318	3.364	3.678	.06170	1.047	.882	27.70	13,850.0	12.5
4	4.500	40	.237	4.026	3.173	.08840	1.178	1.055	39.6	19,800.0	10.8
		80	.337	3.826	4.407	.07986	1.178	1.002	35.8	17,900.0	15.0
		120	.437	3.626	5.578	.07170	1.178	0.950	32.2	16,100.0	19.0
		160	.531	3.438	6.621	.06447	1.178	0.901	28.9	14,450.0	22.6
5	5.563	40	.258	5.047	4.304	.1390	1.456	1.322	62.3	31,150.0	14.7
		80	.375	4.813	6.112	.1263	1.456	1.263	57.7	28,850.0	20.8
		120	.500	4.563	7.953	.1136	1.456	1.197	51.0	25,500.0	27.1
		160	.625	4.313	9.696	.1015	1.456	1.132	45.5	22,750.0	33.0
6	6.625	40	.280	6.065	5.584	.2006	1.734	1.590	90.0	45,000.0	19.0
		80	.432	5.761	8.405	.1810	1.734	1.510	81.1	40,500.0	28.6
		120	.562	5.501	10.71	.1650	1.734	1.445	73.9	36,950.0	36.4
		160	.718	5.189	13.32	.1469	1.734	1.360	65.8	32,900.0	45.3
8	8.625	20	.250	8.125	6.570	.3601	2.258	2.130	161.5	80,750.0	22.4
		30	.277	8.071	7.260	.3553	2.258	2.115	159.4	79,700.0	24.7
		40	.322	7.981	8.396	.3474	2.258	2.090	155.7	77,850.0	28.6
		60	.406	7.813	10.48	.3329	2.258	2.050	149.4	74,700.0	35.7
		80	.500	7.625	12.76	.3171	2.258	2.000	142.3	71,150.0	43.4
		100	.593	7.439	14.96	.3018	2.258	1.947	135.3	67,650.0	50.9
		120	.718	7.189	17.84	.2819	2.258	1.883	126.5	63,250.0	60.7
		140	.812	7.001	19.93	.2673	2.258	1.835	120.0	60,000.0	67.8
		180	.906	6.813	21.97	.2532	2.258	1.787	113.5	56,750.0	74.7

* Based on A.S.A. Standards B36.10.

By permission from Chemical Engineers' Handbook by John H. Perry, Editor. Copyright, 1950. McGraw-Hill Book Company, Inc.

Table 5 — Average Properties of Tubes

DIAMETER		THICKNESS		EXTERNAL			INTERNAL				
External Inches	Internal Inches	BWG Gauge	NOM Wall	Circumference Inches	Surface Per Lineal Foot Square Feet	Lineal Feet of Tube Per Square Foot of Surface	Transverse Area Square Inches	VOLUME OR CAPACITY PER LINEAL FOOT			Length of Tube Containing One Cubic Foot
								Cubic Inches	Cubic Feet Also Area in Square Feet	United States Gallons	
5/8	0.527	18	0.049	1.9635	0.1636	6.1115	0.218	2.616	0.0015	0.011	661
	0.495	16	0.065				0.193	2.316	0.0013	0.010	746
	0.459	14	0.083				0.166	1.992	0.0011	0.009	867
3/4	0.652	18	0.049	2.3562	0.1963	5.0930	0.334	4.008	0.0023	0.017	431
	0.620	16	0.065				0.302	3.624	0.0021	0.016	477
	0.584	14	0.083				0.268	3.216	0.0019	0.014	537
	0.560	13	0.095				0.246	2.952	0.0017	0.013	585
1	0.902	18	0.049	3.1416	0.2618	3.8197	0.639	7.668	0.0044	0.033	225
	0.870	16	0.065				0.595	7.140	0.0041	0.031	242
	0.834	14	0.083				0.546	6.552	0.0038	0.028	264
	0.810	13	0.095				0.515	6.180	0.0036	0.027	280
1 1/4	1.152	18	0.049	3.9270	0.3272	3.0558	1.075	12.90	0.0075	0.056	134
	1.120	16	0.065				0.985	11.82	0.0068	0.051	146
	1.084	14	0.083				0.923	11.08	0.0064	0.048	156
	1.060	13	0.095				0.882	10.58	0.0061	0.046	163
	1.032	12	0.109				0.836	10.03	0.0058	0.043	172
1 1/2	1.402	18	0.049	4.7124	0.3927	2.5465	1.544	18.53	0.0107	0.080	93
	1.370	16	0.065				1.474	17.69	0.0102	0.076	98
	1.334	14	0.083				1.398	16.78	0.0097	0.073	103
	1.310	13	0.095				1.343	16.12	0.0093	0.070	107
	1.282	12	0.109				1.292	15.50	0.0090	0.067	111
1 3/4	1.620	16	0.065	5.4978	0.4581	2.1827	2.061	24.73	0.0143	0.107	70
	1.584	14	0.083				1.971	23.65	0.0137	0.102	73
	1.560	13	0.095				1.911	22.94	0.0133	0.099	75
	1.532	12	0.109				1.843	22.12	0.0128	0.096	78
	1.490	11	0.120				1.744	20.92	0.0121	0.090	83
2	1.870	16	0.065	6.2832	0.5236	1.9099	2.746	32.96	0.0191	0.143	52
	1.834	14	0.083				2.642	31.70	0.0183	0.137	55
	1.810	13	0.095				2.573	30.88	0.0179	0.134	56
	1.782	12	0.109				2.489	29.87	0.0173	0.129	58
	1.760	11	0.120				2.433	29.20	0.0169	0.126	59

**Figure 24 — Overall Heat Transfer Coefficient
Clean vs. Dirty**

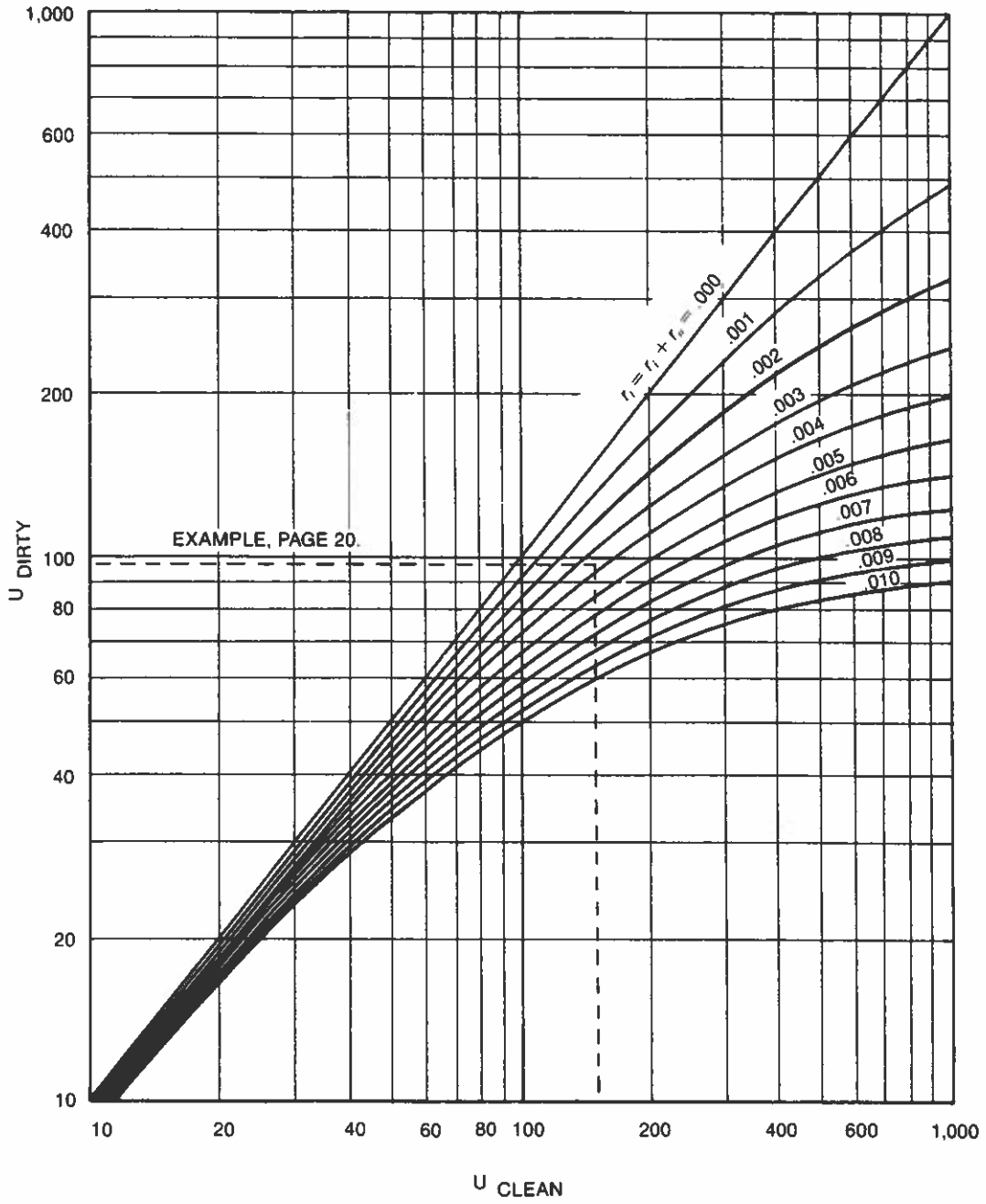

Table 6 — Industrial Design Fouling Resistance
(hr) (sq ft) (°F.)/Btu

Oils:	
Fuel Oil.....	0.005
Quenching Oil.....	0.004
Vegetable Oil.....	0.003
Transformer Oil.....	0.001
Refined Oil.....	0.001
Gases—Vapors:	
Organic Vapor.....	0.0005
Air.....	0.002
Liquids:	
Organic.....	0.001
Brine (Cooling).....	0.001

Table 7 — Miscellaneous Overall Heat Transfer Coefficients¹

	Equipment	Material Treated	Agitation	Heating Surface	Overall Coeff. Btu/hr. Ft. ² F.	Controlling Resistance
Steam	Paper Drying Rolls	Paper		Cast Iron	20-58	Paper Film*
Steam	Yankee Drying Rolls	Paper		Cast Iron	100	Metal Wall*
Steam	Jacketed Kettle	Paraffin Wax	None	Copper	27.4	Product†
Steam	Jacketed Kettle	Paraffin Wax	Scraper	Cast Iron	107	Product†
Steam	Jacketed Kettle	Boiling Water	None	Steel	187	Product†
DOWTHERM A (Vapor phase)	Jacketed Kettle	Varnish	None	Steel	20-50	Product
DOWTHERM A (Vapor phase)	Jacketed Kettle	Asphalt	None	Steel	8-20	Product
DOWTHERM A (Vapor phase)	Heat Exchanger	Fatty Acids	Forced Circn.	Steel	45-50	Product
DOWTHERM A (Vapor phase)	Heat Exchanger	Rosin	Forced Circn.	Steel	40	Product
DOWTHERM A (Vapor phase)	Heat Exchanger	Asphalt	Forced Circn.	Steel	25-50	Product
DOWTHERM A (Vapor phase)	Reboiler	Fatty Acids	None	Steel	80	Product
DOWTHERM A (Liquid phase)	Jacketed Kettle	Varnish	Forced Circn.	Steel	15-40	Product
DOWTHERM A (Vapor phase)	Heat Exchanger	Edible Oil	Forced Circn.	Steel	124-150	Product
DOWTHERM A (Vapor phase)	Heat Exchanger	Coco Butter	Forced Circn.	Steel	70-75	Product
Mercury Vapor	Heat Exchanger	DOWTHERM A Medium	Forced Circn.	Steel	220-350	Product

Approximate Overall Design Coefficients¹

	Hot Fluid	Cold Fluid	Overall U
Coolers	Light Organic	Water	75-150
Heaters	Steam	Light Organic	100-200
Exchangers	Light Organic	Light Organic	40-75
	Heavy Organic	Light Organic	30-60
	Light Organic	Heavy Organic	10-40

¹ Process Heat Transfer, Kern, 840 (1950) 1st Ed. (Values include dirt factors of 0.003 and allowable pressure drops at 5-10 psi on the controlling steam) DOWTHERM fluid would be included as light organic).

* Paper Trade J., Oct. 3, 1946, P. 29, A. E. Montgomery "Heat Transfer Calens. In Paper Machine."

† Chem. Engrs. Handbook, Perry, P. 482, (1950). Third Ed.

Table 8 — Thermal Resistance of Pipes and Tubing

The resistance of the tube or pipe wall referred to its outside surface, may be calculated from the following equation:

$$r_w = (\text{factor})/k,$$

where r_w ... Wall Resistance, (hr) (sq ft) (°F.)/Btu
 Factor ... From Tables A & B below
 k ... Thermal Conductivity, Btu/(hr) (sq ft) (°F./ft.)

Table A — Tubing

Tube Size (O.D.) in.	BWG	Factor
¼	18	0.005185
	20	0.003423
	22	0.002645
	24	0.002017
⅜	16	0.006651
	18	0.004733
	20	0.003228
	22	0.002513
½	12	0.011931
	14	0.008405
	16	0.006274
	18	0.004545
¾	10	0.014503
	12	0.011108
	14	0.007995
	16	0.006038
1	8	0.016686
	10	0.012998
	12	0.010247
	14	0.007562
1¼	8	0.015965
	10	0.012568
	12	0.009979
	14	0.007420
1½	8	0.015529
	10	0.012300
	12	0.009813
	14	0.007328
2	8	0.015529
	10	0.012300
	12	0.009813
	14	0.007328
2½	8	0.015529
	10	0.012300
	12	0.009813
	14	0.007328
3	8	0.015529
	10	0.012300
	12	0.009813
	14	0.007328
3½	8	0.015529
	10	0.012300
	12	0.009813
	14	0.007328
4	8	0.015529
	10	0.012300
	12	0.009813
	14	0.007328
4½	8	0.015529
	10	0.012300
	12	0.009813
	14	0.007328
5	8	0.015529
	10	0.012300
	12	0.009813
	14	0.007328
5½	8	0.015529
	10	0.012300
	12	0.009813
	14	0.007328
6	8	0.015529
	10	0.012300
	12	0.009813
	14	0.007328
6½	8	0.015529
	10	0.012300
	12	0.009813
	14	0.007328
7	8	0.015529
	10	0.012300
	12	0.009813
	14	0.007328
7½	8	0.015529
	10	0.012300
	12	0.009813
	14	0.007328
8	8	0.015529
	10	0.012300
	12	0.009813
	14	0.007328
8½	8	0.015529
	10	0.012300
	12	0.009813
	14	0.007328
9	8	0.015529
	10	0.012300
	12	0.009813
	14	0.007328
9½	8	0.015529
	10	0.012300
	12	0.009813
	14	0.007328
10	8	0.015529
	10	0.012300
	12	0.009813
	14	0.007328
10½	8	0.015529
	10	0.012300
	12	0.009813
	14	0.007328
11	8	0.015529
	10	0.012300
	12	0.009813
	14	0.007328
11½	8	0.015529
	10	0.012300
	12	0.009813
	14	0.007328
12	8	0.015529
	10	0.012300
	12	0.009813
	14	0.007328
12½	8	0.015529
	10	0.012300
	12	0.009813
	14	0.007328
13	8	0.015529
	10	0.012300
	12	0.009813
	14	0.007328
13½	8	0.015529
	10	0.012300
	12	0.009813
	14	0.007328
14	8	0.015529
	10	0.012300
	12	0.009813
	14	0.007328
14½	8	0.015529
	10	0.012300
	12	0.009813
	14	0.007328
15	8	0.015529
	10	0.012300
	12	0.009813
	14	0.007328
15½	8	0.015529
	10	0.012300
	12	0.009813
	14	0.007328
16	8	0.015529
	10	0.012300
	12	0.009813
	14	0.007328
16½	8	0.015529
	10	0.012300
	12	0.009813
	14	0.007328
17	8	0.015529
	10	0.012300
	12	0.009813
	14	0.007328
17½	8	0.015529
	10	0.012300
	12	0.009813
	14	0.007328
18	8	0.015529
	10	0.012300
	12	0.009813
	14	0.007328
18½	8	0.015529
	10	0.012300
	12	0.009813
	14	0.007328
19	8	0.015529
	10	0.012300
	12	0.009813
	14	0.007328
19½	8	0.015529
	10	0.012300
	12	0.009813
	14	0.007328
20	8	0.015529
	10	0.012300
	12	0.009813
	14	0.007328
20½	8	0.015529
	10	0.012300
	12	0.009813
	14	0.007328
21	8	0.015529
	10	0.012300
	12	0.009813
	14	0.007328
21½	8	0.015529
	10	0.012300
	12	0.009813
	14	0.007328
22	8	0.015529
	10	0.012300
	12	0.009813
	14	0.007328
22½	8	0.015529
	10	0.012300
	12	0.009813
	14	0.007328
23	8	0.015529
	10	0.012300
	12	0.009813
	14	0.007328
23½	8	0.015529
	10	0.012300
	12	0.009813
	14	0.007328
24	8	0.015529
	10	0.012300
	12	0.009813
	14	0.007328
24½	8	0.015529
	10	0.012300
	12	0.009813
	14	0.007328
25	8	0.015529
	10	0.012300
	12	0.009813
	14	0.007328
25½	8	0.015529
	10	0.012300
	12	0.009813
	14	0.007328
26	8	0.015529
	10	0.012300
	12	0.009813
	14	0.007328
26½	8	0.015529
	10	0.012300
	12	0.009813
	14	0.007328
27	8	0.015529
	10	0.012300
	12	0.009813
	14	0.007328
27½	8	0.015529
	10	0.012300
	12	0.009813
	14	0.007328
28	8	0.015529
	10	0.012300
	12	0.009813
	14	0.007328
28½	8	0.015529
	10	0.012300
	12	0.009813
	14	0.007328
29	8	0.015529
	10	0.012300
	12	0.009813
	14	0.007328
29½	8	0.015529
	10	0.012300
	12	0.009813
	14	0.007328
30	8	0.015529
	10	0.012300
	12	0.009813
	14	0.007328
30½	8	0.015529
	10	0.012300
	12	0.009813
	14	0.007328
31	8	0.015529
	10	0.012300
	12	0.009813
	14	0.007328
31½	8	0.015529
	10	0.012300
	12	0.009813
	14	0.007328
32	8	0.015529
	10	0.012300
	12	0.009813
	14	0.007328
32½	8	0.015529
	10	0.012300
	12	0.009813
	14	0.007328
33	8	0.015529
	10	0.012300
	12	0.009813
	14	0.007328
33½	8	0.015529
	10	0.012300
	12	0.009813
	14	0.007328
34	8	0.015529
	10	0.012300
	12	0.009813
	14	0.007328
34½	8	0.015529
	10	0.012300
	12	0.009813
	14	0.007328
35	8	0.015529
	10	0.012300
	12	0.009813
	14	0.007328
35½	8	0.015529
	10	0.012300
	12	0.009813
	14	0.007328
36	8	0.015529
	10	0.012300
	12	0.009813
	14	0.007328
36½	8	0.015529
	10	0.012300
	12	0.009813
	14	0.007328
37	8	0.015529
	10	0.012300
	12	0.009813
	14	0.007328
37½	8	0.015529
	10	0.012300
	12	0.009813
	14	0.007328
38	8	0.015529
	10	0.012300
	12	0.009813
	14	0.007328
38½	8	0.015529
	10	0.012300
	12	0.009813
	14	0.007328
39	8	0.015529
	10	0.012300
	12	0.009813
	14	0.007328
39½	8	0.015529
	10	0.012300
	12	0.009813
	14	0.007328
40	8	0.015529
	10	0.012300
	12	0.009813
	14	0.007328
40½	8	0.015529
	10	0.012300
	12	0.009813
	14	0.007328
41	8	0.015529
	10	0.012300
	12	0.009813
	14	0.007328
41½	8	0.015529
	10	0.012300
	12	0.009813
	14	0.007328
42	8	0.015529
	10	0.012300
	12	0.009813
	14	0.007328
42½	8	0.015529
	10	0.012300
	12	0.009813
	14	0.007328
43	8	0.015529
	10	0.012300
	12	0.009813
	14	0.007328
43½	8	0.015529
	10	0.012300
	12	0.009813
	14	0.007328
44	8	0.015529
	10	0.012300
	12	0.009813
	14	0.007328
44½	8	0.015529
	10	0.012300
	12	0.009813
	14	0.007328
45	8	0.015529
	10	0.012300
	12	0.009813
	14	0.007328
45½	8	0.015529
	10	0.012300
	12	0.009813
	14	0.007328
46	8	0.015529
	10	0.012300
	12	0.009813
	14	0.007328
46½	8	0.015529
	10	0.012300
	12	0.009813
	14	0.007328
47	8	0.015529
	10	0.012300
	12	0.009813
	14	0.007328
47½	8	0.015529
	10	0.012300
	12	0.009813
	14	0.007328
48	8	0.015529
	10	0.012300
	12	0.009813
	14	0.007328
48½	8	0.015529
	10	0.012300
	12	0.009813
	14	0.007328
49	8	0.015529
	10	0.012300
	12	0.009813
	14	0.007328
49½	8	0.015529
	10	0.012300
	12	0.009813
	14	0.007328
50	8	0.015529
	10	0.012300
	12	0.009813
	14	0.007328
50½	8	0.015529
	10	0.012300
	12	0.009813
	14	0.007328
51	8	0.015529
	10	0.012300
	12	0.009813
	14	0.007328
51½	8	0.015529
	10	0.012300
	12	0.009813
	14	0.007328
52	8	0.015529
	10	0.012300
	12	0.009813
	14	0.007328
52½	8	0.015529
	10	0.012300
	12	0.009813
	14	0.007328
53	8	0.015529
	10	0.012300
	12	0.00981

Figure 25 — Viscosity Conversion

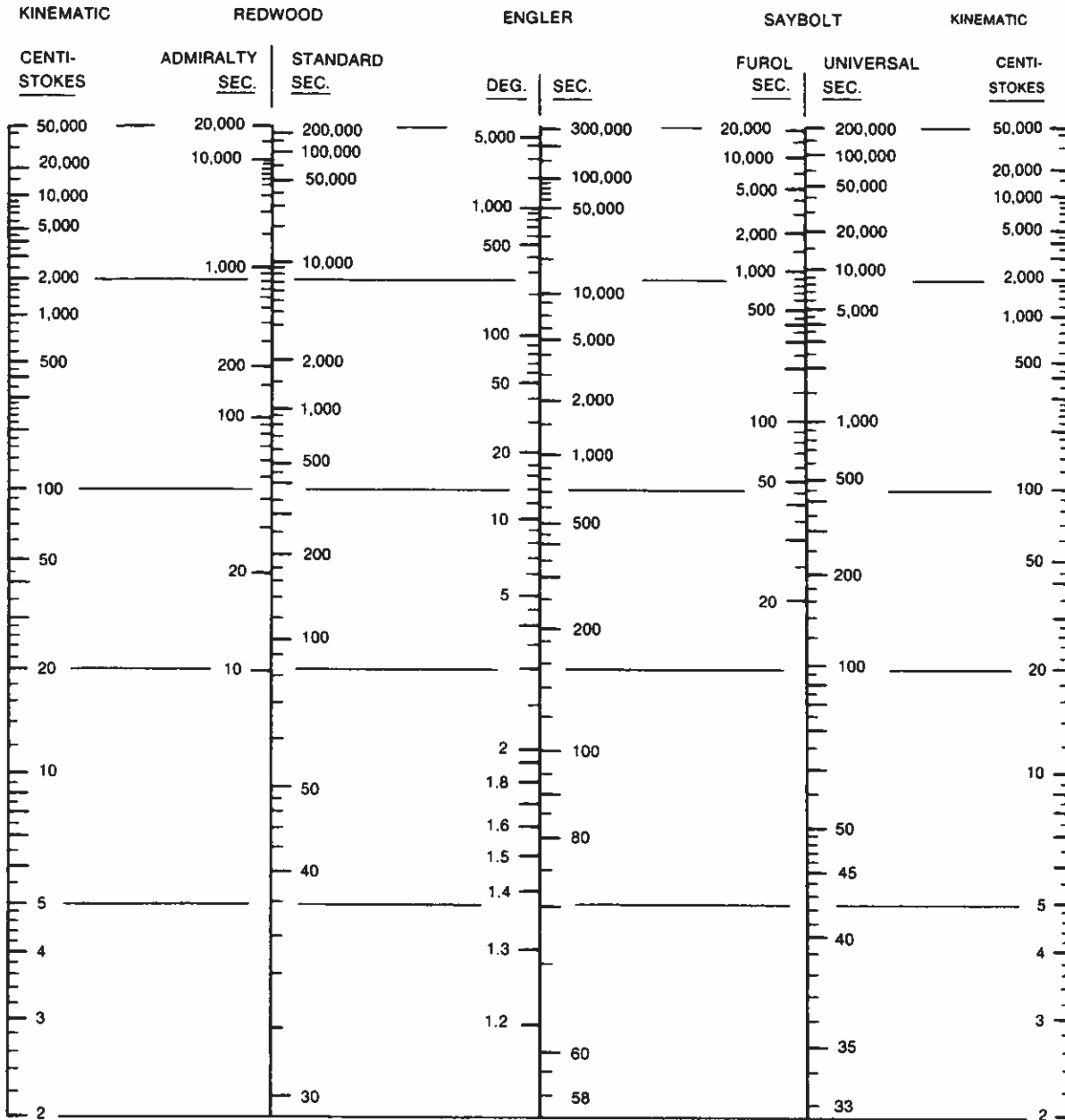

READ HORIZONTALLY ACROSS CHART TO CONVERT READINGS.
 MULTIPLY READINGS IN CENTISTOKES BY SPECIFIC GRAVITY TO
 OBTAIN ABSOLUTE VISCOSITY IN CENTIPOISES.

**Table 9 — Heat Loss From Insulated Pipe
(Btu/Hr)/Linear Ft.**

Nominal Pipe Size	Insulation Thickness Inches	Pipe Temperature, °F.						
		200	300	400	500	600	700	800
2	1.5	28	54	82	112	143	176	210
	2.0	24	46	70	94	121	150	180
4	2.0	38	72	108	146	188	222	282
	2.5	34	63	94	128	164	205	244
6	2.0	50	96	144	196	250	310	370
	3.0	38	73	110	150	192	238	284
8	2.0	60	116	178	242	290	374	460
	3.0	46	86	130	174	226	280	334
10	2.0	74	138	212	284	364	448	540
	3.0	56	104	160	216	276	340	404

Kaylot insulation from catalog of Owens-Corning Fiberglas Corp.
Ambient still air 80°F.

†Trademark of Owens-Corning

**Table 10 — Thermal Conductivity of Insulations
k = Btu/(hr.) (sq. ft.) (°F./inch of Thickness)**

Material	Maximum Temperature	Mean Temperature of Insulation, °F.				
		200	300	400	500	600
Asbestos fibers silicates	1,200° F.	0.37	0.42	0.47	0.52	0.58
Calcium silicate	1,200° F.	0.36	0.42	0.48	0.53	0.58
Laminated Asbestos fiber	700° F.	0.42	0.48	0.54	0.60	
85% Magnesia	600° F.	0.37	0.41	0.46		
Mineral wool	1,700° F.	0.35	0.39	0.43	0.46	0.50
FoamGlas††	900° F.	0.42	0.49	0.59	0.71	

††Trademark of Pittsburgh Corning

Figure 26—Heat Losses From Horizontal Pipe and Bare Iron Surfaces¹

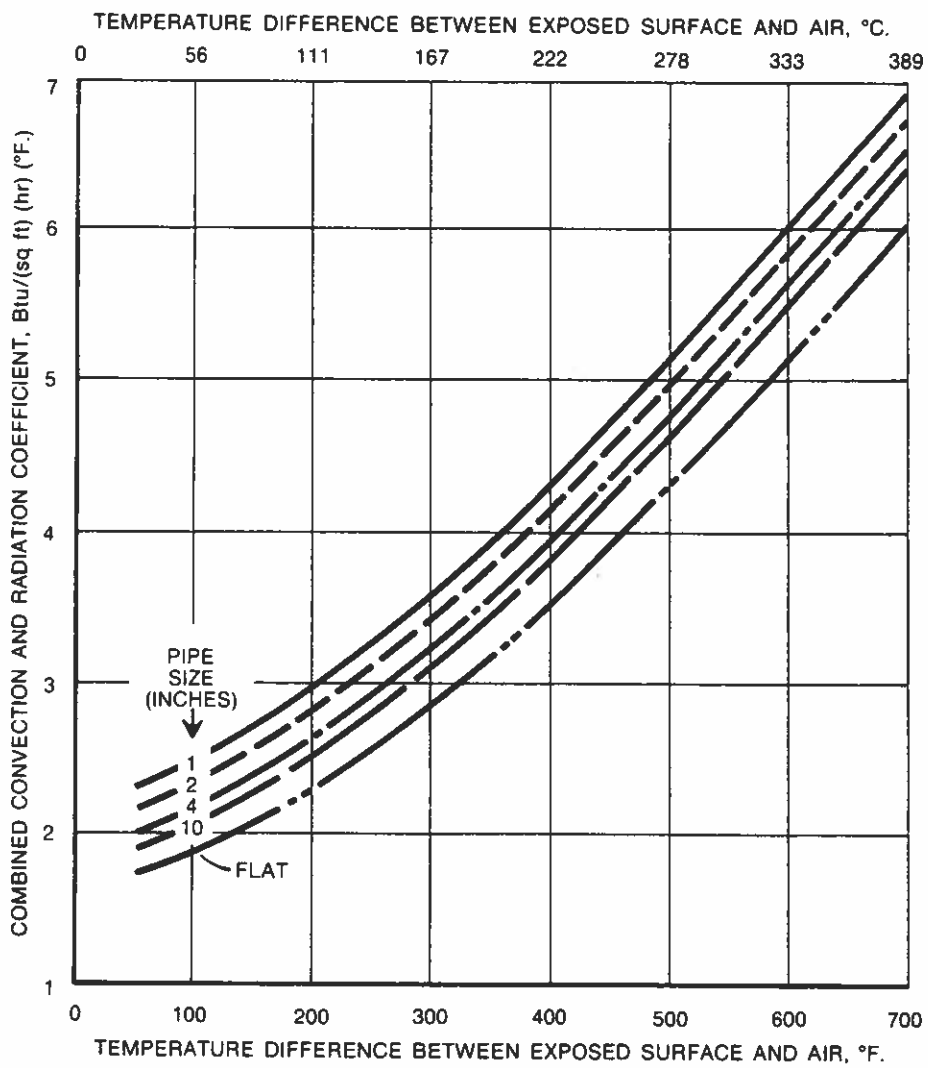

¹Process Heat Transfer, D. Q. Kern, McGraw Hill, 1950, p.18.

**Figure 27 — Effect of Wind Velocity
on Bare or Insulated Surfaces**

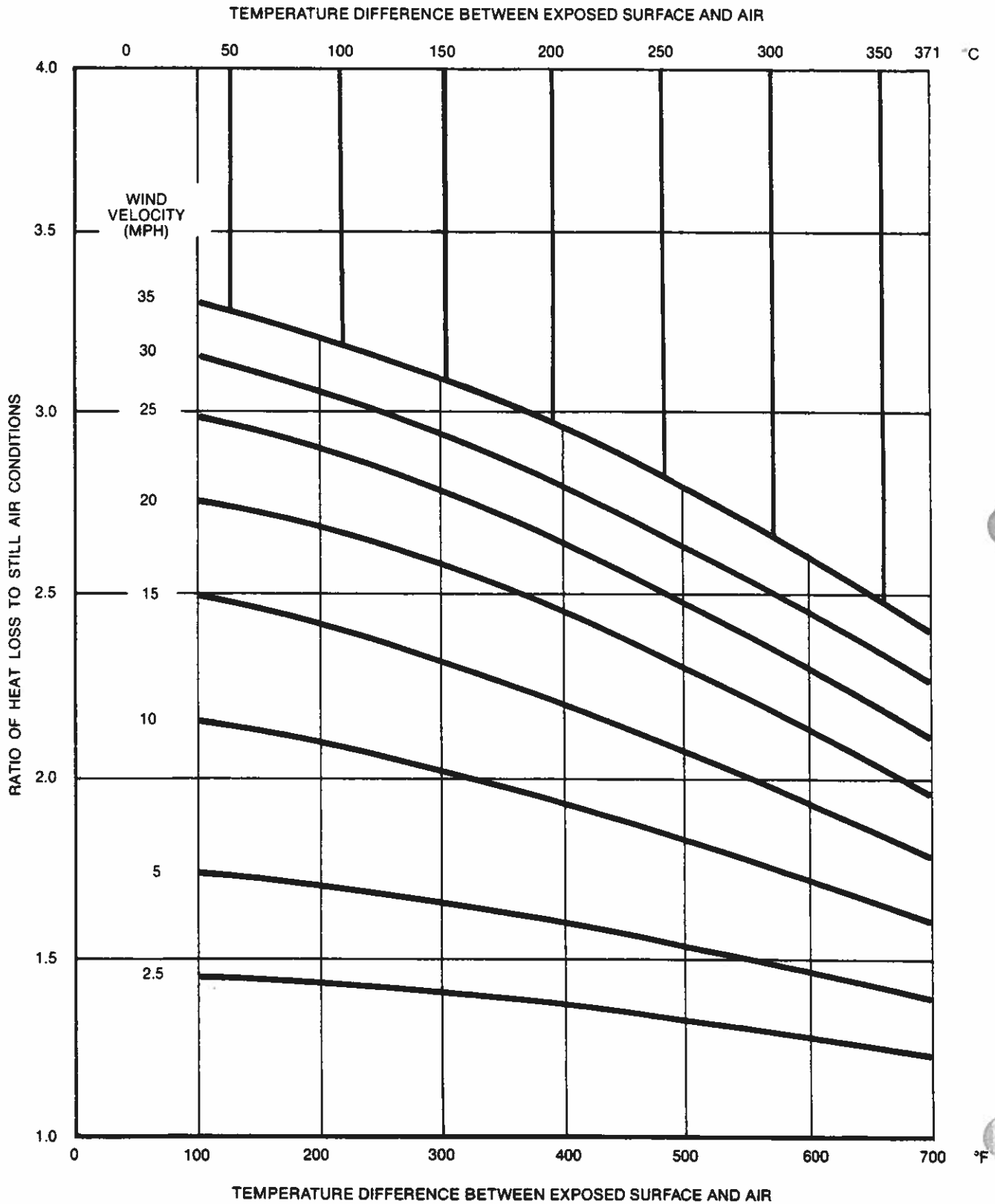
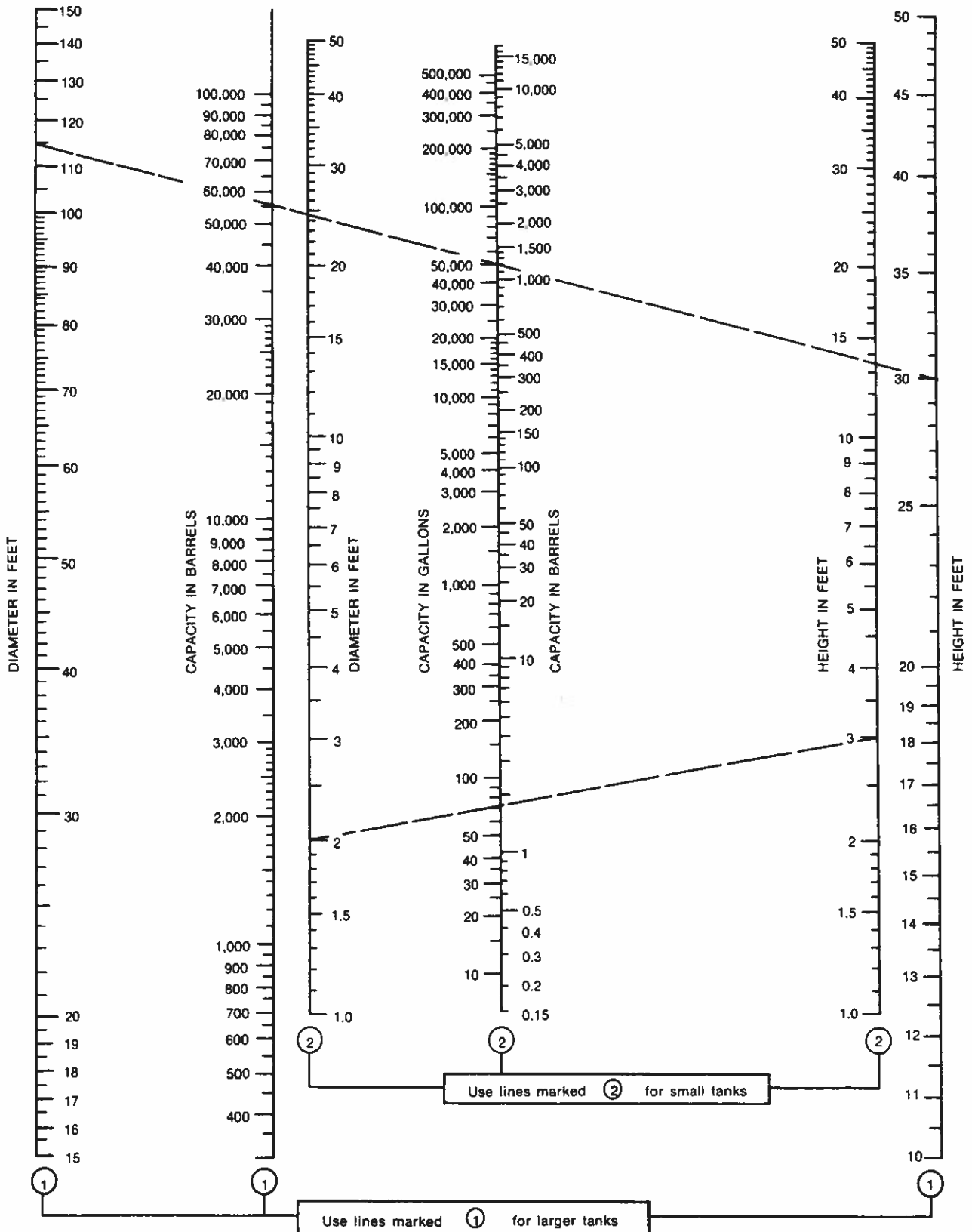

Table 11 — Thermal Expansion Data

Linear Thermal Expansion between 70°F. and Indicated Temperature, Inches/100 feet

Temperature Deg. F.	MATERIAL								Temperature Deg. C.
	Carbon Steel Carbon-Moly Low-Chrome (thru 3 Cr Mo)	5 Cr Mo thru 9 Cr Mo	Austenitic Stainless Steels 18 Cr 8 Ni Alloy	Monel Alloy 67 Ni 30 Cu	3½ Nickel	Aluminum	Brass	Copper	
70	0	0	0	0	0	0	0	0	21.1
100	0.23	0.22	0.34	0.28	0.22	0.46	0.35	0.36	37.8
125	0.42	0.40	0.62	0.52	0.40	0.85	0.64	0.64	51.7
150	0.61	0.58	0.90	0.75	0.58	1.23	0.94	0.95	65.6
175	0.80	0.76	1.18	0.99	0.76	1.62	1.23	1.25	79.4
200	0.99	0.94	1.46	1.22	0.94	2.00	1.52	1.55	93.3
225	1.21	1.13	1.75	1.46	1.13	2.41	1.83	1.85	107.2
250	1.40	1.33	2.03	1.71	1.32	2.83	2.14	2.14	121.1
275	1.61	1.52	2.32	1.96	1.51	3.24	2.45	2.44	135.0
300	1.82	1.71	2.61	2.21	1.69	3.66	2.76	2.74	148.9
325	2.04	1.90	2.90	2.44	1.88	3.84	3.08	3.04	162.8
350	2.26	2.10	3.20	2.68	2.08	4.03	3.41	3.34	176.7
375	2.48	2.30	3.50	2.91	2.27	4.21	3.73	3.64	190.6
400	2.70	2.50	3.80	3.25	2.47	5.39	4.05	3.94	204.4
425	2.93	2.72	4.10	3.52	2.69		4.38	4.24	218.3
450	3.16	2.93	4.41	3.79	2.91		4.72	4.54	232.2
475	3.39	3.14	4.71	4.06	3.13			4.83	246.1
500	3.62	3.35	5.01	4.33	3.34			5.13	260.0
525	3.86	3.58	5.31	4.61	3.57				273.9
550	4.11	3.80	5.62	4.90	3.80				287.8
575	4.35	4.02	5.93	5.18	4.03				301.7
600	4.60	4.24	6.24	5.46	4.27				315.6
625	4.86	4.47	6.55	5.75	4.51				329.4
650	5.11	4.69	6.87	6.05	4.75				343.3
675	5.37	4.92	7.18	6.34	4.99				357.2
700	5.63	5.14	7.50	6.64	5.24				371.1
725	5.90	5.38	7.82	6.94	5.50				385.0
750	6.16	5.62	8.15	7.25	5.76				398.9
775	6.43	5.86	8.47	7.55	6.02				412.8
800	6.70	6.10	8.80	7.85	6.27				426.7
825	6.97	6.34	9.13	8.16	6.54				440.6
850	7.25	6.59	9.46	8.48	6.81				454.4
875	7.53	6.83	9.79	8.80	7.08				468.3
900	7.81	7.07	10.12	9.12	7.35				482.2
925	8.08	7.31	10.46	9.44	7.72				496.1
950	8.35	7.56	10.80	9.77	8.09				510.0
975	8.62	7.81	11.14	10.09	8.46				523.9
1,000	8.89	8.06	11.48	10.42	8.83				537.8

Figure 28 — Tank Capacity Diagram
 (For Approximate Calculations)



From "Petroleum Tankage & Transmission" Graver Tank & Mfg. Co.

Table 12 — Horizontal Cylindrical Tank Volumes (Partly Full)
 Unit Volume (gal./ft. of length)

Dia. of Tank, Ft.	DEPTH OF LIQUID, INCHES																
	3	6	9	12	15	18	21	24	27	30	33	36	39	42	45	48	51
1	1.15	2.94	4.73	5.88													
1½	1.45	3.86	6.61	9.36	11.77	13.22											
2	1.70	4.60	8.05	11.75	15.45	18.90	21.80	23.50									
2½	1.91	5.23	9.27	13.72	18.36	23.00	27.45	31.49	34.81	36.72							
3	2.12	5.79	10.34	15.43	20.85	26.44	32.03	37.45	42.54	47.09	50.76	52.88					
3½	2.28	6.31	11.31	16.97	23.07	29.46	35.99	42.51	48.90	55.00	60.66	65.66	69.69	71.97			
4	2.45	6.78	12.20	18.38	25.10	32.20	39.54	47.01	54.47	61.81	68.91	75.63	81.81	87.23	91.56	94.01	
4½	2.60	7.22	13.04	19.68	26.97	34.72	42.80	51.08	59.49	67.90	76.18	84.26	92.01	99.30	105.94	111.76	116.38
5	2.75	7.64	13.82	20.91	28.72	37.06	45.82	54.88	64.11	73.45	82.78	92.01	101.07	109.83	118.17	125.98	133.07
5½	2.89	8.04	14.56	22.07	30.37	39.28	48.65	58.39	68.42	78.59	88.87	99.14	109.31	119.34	129.08	138.45	147.36
6	3.02	8.42	15.26	23.17	31.92	41.36	51.32	61.71	72.45	83.41	94.54	105.76	116.98	128.11	139.07	149.81	160.20
6½	3.15	8.78	15.94	24.21	33.41	43.34	53.86	64.87	76.27	87.97	99.90	111.97	124.12	136.27	148.34	160.27	171.97
7	3.26	9.12	16.57	25.24	34.85	45.24	56.29	67.87	79.91	92.30	104.96	117.85	130.87	143.95	157.03	170.05	182.92
7½	3.43	9.46	17.20	26.20	36.21	47.05	58.61	70.75	83.39	96.43	109.81	123.46	137.28	151.22	165.25	179.27	193.21
8	3.50	9.79	17.80	27.13	37.52	48.81	60.84	73.52	86.73	100.39	114.44	128.79	143.40	158.17	173.07	188.01	202.95
8½	3.61	10.10	18.37	28.01	39.00	50.49	62.99	76.18	89.94	104.20	118.89	133.92	149.25	164.81	180.53	196.36	212.25
9	3.71	10.39	18.94	28.90	40.03	52.14	65.09	78.74	93.04	107.87	123.17	138.87	154.89	171.19	187.71	204.37	221.15

Dia. of Tank, Ft.	DEPTH OF LIQUID, INCHES																
	54	57	60	63	66	69	72	75	78	81	84	87	90	93	96	102	108
1																	
1½																	
2																	
2½																	
3																	
3½																	
4																	
4½	118.98																
5	139.25	144.14	146.89														
5½	155.66	163.17	169.69	174.84	177.73												
6	170.16	179.60	188.35	196.26	203.10	208.50	211.52										
6½	183.37	194.38	204.90	214.83	224.03	232.30	239.46	245.09	248.24								
7	195.60	207.99	220.03	231.61	242.66	253.05	262.66	271.33	278.78	284.64	287.90						
7½	207.03	220.68	234.06	247.10	259.74	271.88	283.44	294.28	304.29	313.29	321.03	327.06	330.49				
8	217.85	232.62	247.23	261.58	275.63	289.29	302.50	315.18	327.21	338.50	348.89	358.22	366.23	372.52	376.02		
8½	228.12	243.95	259.67	275.23	290.56	305.59	320.28	334.54	348.30	361.49	373.99	385.48	396.47	406.11	414.38	424.48	
9	238.05	254.75	271.53	288.19	304.71	321.01	337.03	352.73	368.03	382.86	397.16	410.81	423.76	435.87	447.00	465.51	475.90

Table 13 — Steam Table

TEMPERATURE		Abs. Press. lbs./sq. in. p	SPECIFIC VOLUME			ENTHALPY			ENTROPY		
Deg. F. t	Deg. C. t		Sat. Liquid v_f	Evap. v_{fg}	Sat. Vapor v_g	Sat. Liquid h_f	Evap. h_{fg}	Sat. Vapor h_g	Sat. Liquid s_f	Evap. s_{fg}	Sat. Vapor
32	0.0	0.06854	0.01602	3306.	3306.	0.00	1075.8	1075.8	0.0000	2.1877	2.1877
35	1.7	0.09995	0.01602	2947.	2947.	3.02	1074.1	1077.1	0.0061	2.1709	2.1770
40	4.4	0.12170	0.01602	2444.	2444.	8.05	1071.3	1079.3	0.0162	2.1435	2.1597
45	7.2	0.14752	0.01602	2036.4	2036.4	13.06	1068.4	1081.5	0.0262	2.1167	2.1429
50	10.0	0.17811	0.01603	1703.2	1703.2	18.07	1065.6	1083.7	0.0361	2.0903	2.1264
60	15.6	0.2563	0.01604	1206.6	1206.7	28.06	1059.9	1088.0	0.0555	2.0393	2.0948
70	21.1	0.3631	0.01606	867.8	867.9	38.04	1054.3	1092.3	0.0745	1.9902	2.0647
80	26.7	0.5069	0.01608	633.1	633.1	48.02	1048.6	1096.6	0.0932	1.9428	2.0360
90	32.2	0.6982	0.01610	468.0	468.0	57.99	1042.9	1100.9	0.1115	1.8972	2.0087
100	37.8	0.9492	0.01613	350.3	350.4	67.97	1037.2	1105.2	0.1295	1.8531	1.9826
110	43.3	1.2748	0.01617	265.3	265.4	77.94	1031.6	1109.5	0.1471	1.8106	1.9577
120	48.9	1.6924	0.01620	203.25	203.27	87.92	1025.8	1113.7	0.1645	1.7694	1.9339
130	54.5	2.2225	0.01625	157.32	157.34	97.90	1020.0	1117.9	0.1816	1.7296	1.9112
140	60.0	2.8886	0.01629	122.99	123.01	107.89	1014.1	1122.0	0.1984	1.6910	1.8894
150	65.6	3.718	0.01634	97.06	97.07	117.89	1008.2	1126.1	0.2149	1.6537	1.8685
160	71.1	4.741	0.01639	77.27	77.29	127.89	1002.3	1130.2	0.2311	1.6174	1.8485
170	76.7	5.992	0.01645	62.04	62.06	137.90	996.3	1134.2	0.2472	1.5822	1.8293
180	82.2	7.510	0.01651	50.21	50.23	147.92	990.2	1138.1	0.2630	1.5480	1.8109
190	87.8	9.339	0.01657	40.94	40.96	157.95	984.1	1142.0	0.2785	1.5147	1.7932
200	93.3	11.526	0.01663	33.62	33.64	167.99	977.9	1145.9	0.2938	1.4824	1.7762
210	98.9	14.123	0.01670	27.80	27.82	178.05	971.6	1149.7	0.3090	1.4508	1.7598
212	100.0	14.696	0.01672	26.78	26.80	180.07	970.3	1150.4	0.3120	1.4446	1.7566
220	104.4	17.186	0.01677	23.13	23.15	188.13	965.2	1153.4	0.3239	1.4201	1.7440
230	110.0	20.780	0.01684	19.365	19.382	198.23	958.8	1157.0	0.3387	1.3901	1.7288
240	115.6	24.969	0.01692	16.306	16.323	208.34	952.2	1160.5	0.3531	1.3609	1.7140
250	121.1	29.825	0.01700	13.804	13.821	218.48	945.5	1164.0	0.3675	1.3323	1.6998
260	126.7	35.429	0.01709	11.746	11.763	228.64	938.7	1167.3	0.3817	1.3043	1.6860
270	132.2	41.858	0.01717	10.044	10.061	238.84	931.8	1170.6	0.3958	1.2769	1.6727
280	137.8	49.203	0.01726	8.628	8.645	249.06	924.7	1173.8	0.4096	1.2501	1.6597
290	143.3	57.556	0.01735	7.444	7.461	259.31	917.5	1176.8	0.4234	1.2238	1.6472
300	148.9	67.013	0.01745	6.449	6.466	269.59	910.1	1179.7	0.4369	1.1980	1.6350
310	154.4	77.68	0.01755	5.609	5.626	279.92	902.6	1182.5	0.4504	1.1727	1.6231
320	160.0	89.66	0.01765	4.896	4.914	290.28	894.9	1185.2	0.4637	1.1478	1.6115
330	165.6	103.06	0.01776	4.289	4.307	300.68	887.0	1187.7	0.4769	1.1233	1.6002
340	171.1	118.01	0.01787	3.770	3.788	311.13	879.0	1190.1	0.4900	1.0992	1.5891
350	176.7	134.63	0.01799	3.324	3.342	321.63	870.7	1192.3	0.5029	1.0754	1.5783
360	182.2	153.04	0.01811	2.939	2.957	332.18	862.2	1194.4	0.5158	1.0519	1.5677
370	187.8	173.37	0.01823	2.606	2.625	342.79	853.5	1196.3	0.5286	1.0287	1.5573
380	193.3	195.77	0.01836	2.317	2.335	353.45	844.6	1198.1	0.5413	1.0059	1.5471
390	198.9	220.37	0.01850	2.0651	2.0836	364.17	835.4	1199.6	0.5539	0.9832	1.5371
400	204.4	247.31	0.01864	1.8447	1.8633	374.97	826.0	1201.0	0.5664	0.9608	1.5272
410	210.0	276.75	0.01878	1.6512	1.6700	385.83	816.3	1202.1	0.5788	0.9388	1.5174
420	215.6	308.83	0.01894	1.4811	1.5000	396.77	806.3	1203.1	0.5912	0.9166	1.5078
430	221.1	343.72	0.01910	1.3308	1.3499	407.79	796.0	1203.8	0.6035	0.8947	1.4982
440	226.7	381.59	0.01926	1.1979	1.2171	418.90	785.4	1204.3	0.6158	0.8730	1.4887
450	232.2	422.6	0.0194	1.0799	1.0993	430.1	774.5	1204.6	0.6280	0.8513	1.4793
460	237.8	466.9	0.0196	0.9748	0.9944	441.4	763.2	1204.6	0.6402	0.8298	1.4700
470	243.3	514.7	0.0198	0.8811	0.9009	452.8	751.5	1204.3	0.6523	0.8083	1.4606
480	248.9	566.1	0.0200	0.7972	0.8172	464.4	739.4	1203.7	0.6645	0.7868	1.4513
490	254.4	621.4	0.0202	0.7221	0.7423	476.0	726.8	1202.8	0.6766	0.7653	1.4419
500	260.0	680.8	0.0204	0.6545	0.6749	487.8	713.9	1201.7	0.6887	0.7438	1.4325
520	271.1	812.4	0.0209	0.5385	0.5594	511.9	686.4	1198.2	0.7130	0.7006	1.4136
540	282.2	962.5	0.0215	0.4434	0.4649	536.6	656.6	1193.2	0.7374	0.6568	1.3942
560	293.3	1133.1	0.0221	0.3647	0.3868	562.2	624.2	1186.4	0.7621	0.6121	1.3742
580	304.4	1325.8	0.0228	0.2989	0.3217	588.9	588.4	1177.3	0.7872	0.5659	1.3532
600	315.6	1542.9	0.0236	0.2432	0.2668	617.0	548.5	1165.5	0.8131	0.5176	1.3307
620	326.7	1786.6	0.0247	0.1955	0.2201	646.7	503.6	1150.3	0.8398	0.4664	1.3082
640	337.8	2059.7	0.0260	0.1538	0.1798	678.6	452.0	1130.5	0.8679	0.4110	1.2789
660	348.9	2365.4	0.0278	0.1165	0.1442	714.2	390.2	1104.4	0.8987	0.3485	1.2472
680	360.0	2708.1	0.0305	0.0810	0.1115	757.3	309.9	1067.2	0.9351	0.2719	1.2071
700	371.1	3093.7	0.0369	0.0392	0.0761	823.3	172.1	995.4	0.9905	0.1484	1.1389
705.4	374.1	3206.2	0.0503	0	0.0503	902.7	0	902.7	1.0580	0	1.0580

Table 14 — Frequently Used Engineering Conversion Factors

Multiply	By	To Obtain
Atmospheres	76.0	Cm. mercury
Atmospheres	29.92	In. mercury
Atmospheres	33.90	Ft. water
Atmospheres	10.333	Kg./meter ²
Atmospheres	14.70	Lb./in. ²
Btu	0.2520	Kcal
Btu	777.5	Ft.-lb.
Btu	3.927 x 10 ⁻⁴	Horsepower-hr.
Btu	107.5	Kg.-meters
Btu	2.928 x 10 ⁻⁴	Kw.-hr.
Btu	252	Gcal
Btu/min	12.96	Ft.-lb./sec.
Btu/min	0.02356	Horsepower
Btu/min	0.01757	Kilowatts
Btu/min	17.57	Watts
Btu/(hr.) (ft. ²) (°F.)	4.882	Kcal/(hr.) (m. ²) (°C.)
Btu/(hr.) (ft. ²) (°F.)	1.0	*P.C.U./(hr.) (ft. ²) (°C.)
Btu/(hr.) (ft. ²) (°F.)	1.35 x 10 ⁻⁶	Gcal/(sec.) (cm. ²) (°C.)
Btu/(hr.) (ft. ²) (°F.)	2.04 x 10 ⁻³	Watts/(in. ²) (°F.)
Btu/(hr.) (ft. ²) (°F.)	5.68 x 10 ⁻⁶	Watts/(cm. ²) (°C.)
Btu/(hr.) (ft. ²) (°F./ft.)	12	Btu/(hr.) (ft. ²) (°F./in.)
Btu/(hr.) (ft. ²) (°F./ft.)	0.0173	Watts/(cm. ²) (°C./cm.)
Btu/(hr.) (ft. ²) (°F./ft.)	0.00413	Gcal/(sec.) (cm. ²) (°C./cm.)
Btu/(hr.) (ft. ²) (°F./ft.)	14.88	Cal/(hr.) (cm. ²) (°C./cm.)
Btu/(hr.) (ft. ²) (°F./ft.)	168	Btu/(day) (ft. ²) (°F./m.)
Btu/(hr.) (ft. ²) (°F./ft.)	0.00144	Watts/(cm. ²) (°C./cm.)
Btu/(hr.) (ft. ²) (°F./ft.)	0.0003444	Gcal/(sec.) (cm. ²) (°C./cm.)
Btu/(hr.) (ft. ²) (°F./ft.)	12.4	Kcal/(hr.) (m. ²) (°C./cm.)
Btu/sec	1.415	Hp. (550 std. ft.-lb./sec.)
Btu/sec	1.434	Metric horsepower
Btu/sec	1.055	Kilowatts
Btu/sec	778.2	Ft.-b./sec.
Btu/sec	252	Gcal/sec
Btu/sec	0.1075	Boiler horsepower
Btu/sec	3600	Btu/hr.
Btu/hr.	3.927 x 10 ⁻⁴	Horsepower
Btu/ft. ³	8.90	Kcal/m. ³
Btu/ft. ³	2.712	Kcal/(hr.) (m. ²)
Btu/lb.	0.5556	Gcal/gm.
Btu/(lb.) (°F.)	1	Kcal/(kg.) (°C.)
Centimeters	0.393	Inches
Centimeters mercury	0.01316	Atmospheres
Centimeters mercury	0.4461	Ft. water
Centimeters mercury	136.0	Kg./m. ³
Centimeters mercury	27.85	Lb./ft. ³
Centimeters mercury	0.1934	Lb./in. ³
Calories	0.00396	Btu
Cal./gm.	1	Kcal/kg.
Centipoises	0.01	(g. (sec.) (cm.)
Centipoises	2.42	English Hours (lb./hr.) (ft.)
Centipoises	6.72 x 10 ⁻⁴	English Seconds (lb./sec.) (ft.)
Centipoises	3.60	Kg./m. (hr.)
English Seconds (lb./m.) (ft.)	3600	English Hours (lb./hr.) (ft.)
(lb./m.) (ft.)	14.87	Poises (g./sec.) (cm.)
(lb./m.) (ft.)	1487	Centipoises
Ft. water	0.02950	Atmospheres
Ft. water	0.8826	In. mercury
Ft. water	304.8	Kg./meter ²
Ft. water	62.43	Lb./ft. ²
Ft. water	0.4335	Lb./in. ²
Ft./min.	0.5080	Cm./sec.
Ft./min.	0.01667	Ft./sec.
Ft./min.	0.01829	Km./hr.
Ft./min.	0.3048	Meters/min.
Ft./min.	0.005080	Meters/sec.
Ft. ³ /lb.	62.43	Cm. ³ /gm.
Ft. ³ /min.	472	Cm. ³ /sec.
Ft. ³ /min.	0.1247	Gal./sec.

* Pound-centigrade unit.

Multiply	By	To Obtain
Ft. ³ /sec.	448.8	Gal./min.
Ft. ³ (/sec.) (ft. ³)	0.0305	Liters/(sec.) (cm. ³)
Ft./sec.	30.48	Cm./sec.
Ft./sec.	18.29	Meters/min.
Ft.-lbs.	1.286 x 10 ⁻³	Btu
Ft.-lbs.	5.050 x 10 ⁻⁷	Horsepower-hr.
Ft.-lbs.	3.241 x 10 ⁻⁴	Kcal
Ft.-lbs.	0.1383	Kg.-meters
Ft.-lbs.	3.766 x 10 ⁻⁷	Kw.-hr.
Ft.-lbs./min	1.286 x 10 ⁻³	Btu/min.
Ft.-lbs./min	0.01667	Ft.-lb./sec.
Ft.-lbs./min	3.030 x 10 ⁻⁵	Horsepower
Ft.-lbs./min	3.241 x 10 ⁻⁴	Kcal/min.
Ft.-lbs./min	2.260 x 10 ⁻⁵	Kilowatts
Ft.-lbs./sec	7.717 x 10 ⁻²	Btu/min.
Ft.-lbs./sec	1.818 x 10 ⁻³	Horsepower
Ft.-lbs./sec	1.945 x 10 ⁻²	Kcal/min.
Ft.-lbs./sec	1.356 x 10 ⁻³	Kilowatts
Ft.-lbs./sec	0.00184	Metric horsepower
Ft.-lbs./sec	0.3241	Gcal/sec.
Ft.-lbs./sec	0.00182	Boiler horsepower
Ft.-lbs./sec	4.626	Btu/hr.
Gallons	3785	Centimeters ³
Gallons	0.1337	Feet ³
Gallons	3.785 x 10 ⁻³	Meters ³
Gallons, imperial	1.20095	U.S. gallons
Gallons, U.S.	0.83267	Imperial gallons
Gallons water	8.3453	Lb. water
Gallons/min.	2.228 x 10 ⁻³	Ft. ³ /sec.
Gallons/min.	0.06308	Liters/sec.
Gallons/min.	8.0208	Ft. ³ /hr.
Gallons/min.	0.227	Meters ³ /hr.
Gram-calories	3.968 x 10 ⁻³	Btu
Gram-calories	4.186	Joules
Gcal/gram	1.8	Btu/lb.
Gcal/(sec.) (cm. ²) (°C./cm.)	242.13	Btu/(hr.) (ft. ²) (°F./ft.)
Gcal/(sec.) (cm. ²) (°C./cm.)	2905.6	Btu/(hr.) (ft. ²) (°F./in.)
Gcal/(sec.) (cm. ²) (°C./cm.)	6.6366	Watts/(cm. ²) (°C./cm.)
Gcal/(sec.) (cm. ²) (°C.)	7.380	Btu/(hr.) (ft. ²) (°F.)
Gcal/(sec.) (cm. ²) (°C.)	36.010	Kcal/(hr.) (m. ²) (°C.)
Gcal/(sec.) (cm. ²) (°C.)	15.05	Watts/(in. ²) (°F.)
Gcal/(sec.) (cm. ²) (°C.)	41.92	Watts/(cm. ²) (°C.)
Gram-centimeters	9.294 x 10 ⁻⁸	Btu
Gm./cm. ³	62.43	Lb./ft. ³
Gm./cm. ³	0.03613	Lb./in. ³
Horsepower	42.44	Btu/min.
Horsepower	33,000	Ft.-lb./min.
Horsepower	550	Ft.-lb./sec.
Horsepower	1.014	Horsepower (metric)
Horsepower	10.70	Kcal/min.
Horsepower	0.7457	Kilowatts
Horsepower	745.7	Watts
Horsepower	2544.5	Btu/hr.
Horsepower	178.26	Gcal/sec
Horsepower	0.0760	Boiler horsepower
Horsepower (boiler)	33,479	Btu/hr.
Horsepower (boiler)	9.803	Kilowatts
Horsepower (boiler)	2343.1	Gcal/sec.
Horsepower (boiler)	13.14	Horsepower
Horsepower (boiler)	13.32	Metric horsepower
Horsepower (boiler)	7229.9	Ft.-lb./sec.
Horsepower hours	2547	Btu
Horsepower hours	1.98 x 10 ⁶	Ft.-lb.
Horsepower hours	641.7	Kcal
Horsepower hours	2.737 x 10 ⁵	Kg.-meters
Horsepower hours	0.7457	Kw.-hr.
Inches	2.54	Cm.
Inches mercury	0.03342	Atmospheres
Inches mercury	1.133	Ft. water
Inches mercury	345.3	Kg./meter ²

Table 14 — Continued
Frequently Used Engineering Conversion Factors

Multiply	By	To Obtain
Inches mercury	70.73	Lb./ft. ²
Inches mercury	0.4912	Lb./in. ²
Inches water	0.002458	Atmospheres
Inches water	0.07355	In. mercury
Inches water	25.40	Kg./meter ²
Inches water	0.5781	oz./in. ²
Inches water	5.202	Lb./ft. ²
Inches water	0.03613	Lb./in. ²
Inches water	0.1869	Cm. mercury
Joules	1 x 10 ⁷	Ergs
Joules	2.39 x 10 ⁻⁴	Kg.-cal.
Joules	0.102	Kg.-meters
Joules	2.778 x 10 ⁻⁴	Watt hr.
Joules	5.265 x 10 ⁻⁴	P.c.u.
Joules	0.7378	Ft.-lb.
Joules	9.486 x 10 ⁻⁴	Btu
Joules/gram	0.4305	Btu/lb.
Joules/(gram) (°C.)	0.2389	Btu/(lb.) (°F.)
Kilograms	9.807 x 10 ⁵	Dynes
Kilograms	70.93	Poundals
Kilograms	2.205	Pounds
Kilogram-calories	3.968	Btu
Kilogram-calories	3086	Ft.-lb.
Kilogram-calories	1.558 x 10 ⁻³	Horsepower-hr.
Kilogram-calories	1.162 x 10 ⁻³	Kw.-hr.
Kilogram-calories	426.6	Kg.-meters
Kcal/min.	51.43	Ft.-lb./sec.
Kcal/min.	0.09351	Horsepower
Kcal/min.	0.06972	Kilowatts
Kg./meter	0.6720	Lb./ft.
Kg./meter	7.233	Ft./lb.
Kg./meter	7.302 x 10 ⁻³	Btu
Kg./meter	2.344 x 10 ⁻³	Kcal
Kg./meter	2.724 x 10 ⁻⁶	Kw.-hr.
Kg./meter ²	0.06243	Lb./ft. ²
Kg./meter ²	9.67 x 10 ⁻³	Atmospheres
Kg./meters ²	3.281 x 10 ⁻³	Ft. water
Kg./meter ²	2.896 x 10 ⁻³	In. mercury
Kg./meter ²	0.2048	Lb./ft. ²
Kg./meter ²	1.422 x 10 ⁻³	Lb./in. ²
Kg./meter ²	7.355 x 10 ⁻³	Cm. mercury
Kg./mm. ²	10 ⁶	Kg./meter ²
Kcal/kg.	1	Cal./gram
Kg./meter ²	0.0624	Lb./ft. ²
Kcal/(kg.) (°C.)	1	Btu/(lb.) (°F.)
Kcal/(hr.) (m. ²) (°C.)	0.2049	Btu/(hr.) (ft. ²) (°F.)
Kcal/(hr.) (m. ²) (°C.)	0.2049	P.c.u./hr.) (ft. ²) (°F.)
Kcal/(hr.) (m. ²) (°C.)	2.776 x 10 ⁻⁵	Gcal/(sec.) (cm. ²) (°C.)
Kcal/(hr.) (m. ²) (°C.)	4.179 x 10 ⁻⁴	Watts/(in. ²) (°F.)
Kcal/(hr.) (m. ²) (°C.)	1.16 x 10 ⁻⁴	Watts/(cm. ²) (°C.)
Kilowatts	56.92	Btu/min.
Kilowatts	4.425 x 10 ⁴	Ft.-lb./min.
Kilowatts	737.6	Ft.-lb./sec.
Kilowatts	1.341	Horsepower
Kilowatts	14.34	Kg.-cal./min.
Kilowatts	1000	Watts
Kilowatts	1.3596	Metric horsepower
Kilowatts	737.6	Ft.-lb./sec.
Kilowatts	239.0	Gcal/sec.
Kilowatts	0.1019	Boiler horsepower
Kilowatts	3415	Btu/hr.
Kilowatt-hours	3415	Btu
Kilowatt-hours	2.655 x 10 ⁶	Ft.-lb.
Kilowatt-hours	1.341	Horsepower-hr.
Kilowatt-hours	860.5	Kcal
Kilowatt-hours	3.671 x 10 ⁵	Kg.-meters
Liters	0.03531	Feet ³
Liters	1.308 x 10 ⁻³	Yards ³
Liters	0.2642	Gallons
Liters/min.	5.886 x 10 ⁻⁴	Fl. ³ /sec.
Liters/min.	4.403 x 10 ⁻³	Gal./sec.

Multiply	By	To Obtain
Meters/min	1.667	Cm./sec.
Meters/min	3.281	Ft./min.
Meters/min.	0.05468	Ft./sec.
Meters/sec	196.8	Ft./min.
Meters/sec	3.281	Ft./sec.
Metric horsepower	0.9863	Horsepower
Metric horsepower	0.7355	Kilowatts
Metric horsepower	542.5	Ft.-lb./sec.
Metric horsepower	0.6971	Btu/sec.
Metric horsepower	175.82	Gcal/sec.
Metric horsepower	0.0750	Boiler horsepower
Metric horsepower	2509.6	Btu/hr.
Parts/million	8.345	Lb./million gal
Lb. water	0.01602	Fl. ³ of water
Lb. water	27.68	In. ³
Lb. water	0.1198	Gallons
Lb./ft. ³	0.01602	Gram/cm. ³
Lb./ft. ³	16.02	Kg./meters ³
Lb./ft. ³	5.787 x 10 ⁻⁴	Lb./in. ³
Lb./in. ³	27.68	Gram/cm. ³
Lb./in. ³	2.768 x 10 ⁴	Kg./meters ³
Lb./in. ³	1728	Lb./ft. ³
Lb./ft.	1.488	Kg./meter
Lb./in.	178.6	Gm./cm.
Lb./ft. ²	0.01602	Ft. water
Lb./ft. ²	4.883	Kg./meter ²
Lb./ft. ²	6.945 x 10 ⁻³	Lb./in. ²
Lb. (ft.) (hr.)	4.13 x 10 ⁻³	Gram/(cm.) (sec.)
Lb. (ft.) (hr.)	0.413	Centipoises
Lb./in. ²	0.06804	Atmospheres
Lb./in. ²	2.307	Ft. water
Lb./in. ²	2.036	In. mercury
Lb./in. ²	703.1	Kg./meter ²
Lb./in. ²	51.7	Mm. mercury
Lb./in. ²	144	Lb./ft.
Quintal, Argentina	101.28	Pounds
Quintal, Brazil	129.54	Pounds
Quintal, Castile, Peru	101.43	Pounds
Quintal, Chile	101.41	Pounds
Quintal, Mexico	101.47	Pounds
Quintal, Metric	220.46	Pounds
Temperature °C. + 273	1.0	Abs. temp. °K.
Temperature °F. + 460	1.0	Abs. temp. °R.
Watts	0.05692	Btu/min.
Watts	44.26	Ft.-lb./min.
Watts	0.7376	Ft.-lb./sec.
Watts	1.341 x 10 ⁻³	Horsepower
Watts	0.01434	Kcal/min.
Watts	1.0 x 10 ⁻³	Kilowatts
Watt-hours	3.415	Btu
Watt-hours	2655	Ft.-lb.
Watt-hours	1.341 x 10 ⁻³	Horsepower-hr.
Watt-hours	0.8605	Kcal
Watt-hours	367.1	Kg.-meters
Watt-hours	1 x 10 ⁻³	Kilowatt-hr.
Watts/(cm. ²) (°C./cm.)	57.8	Btu/(hr.) (ft. ²) (°F./ft.)
Watts/(cm. ²) (°C./cm.)	693.6	Btu/(hr.) (ft. ²) (°F./in.)
Watts/(cm. ²) (°C./cm.)	.90023	Gcal/(sec.) (cm. ²) (°C./cm.)
Watts/(hr.) (ft. ²) (°F.)	490	Btu/(hr.) (ft. ²) (°F.)
Watts/(in. ²) (°F.)	7.390	Kcal/(hr.) (m. ²) (°C.)
Watts/(in. ²) (°F.)	0.05640	Gcal/(sec.) (cm. ²) (°C.)
Watts/(in. ²) (°F.)	2.78	Watts/(cm. ²) (°C.)
Watts/(cm. ²) (°C.)	1.760	Btu/(hr.) (ft. ²) (°F.)
Watts/(cm. ²) (°C.)	8.589	Kcal/(hr.) (m. ²) (°C.)
Watts/(cm. ²) (°C.)	0.2385	Gcal/(sec.) (cm. ²) (°C.)
Watts/(cm. ²) (°C.)	0.0359	Watts/(in. ²) (°F.)
Years (common)	8.76 x 10 ³	Hours

$$^{\circ}\text{C.} = \frac{^{\circ}\text{F.} - 32}{1.8}$$

$$^{\circ}\text{F.} = 1.8^{\circ}\text{C.} + 32$$

ENGINEERING MANUAL
FOR DOWTHERM
HEAT TRANSFER FLUIDS

For further information, call...

In The United States And Canada: 1-800-447-4369; Fax: 1-989-832-1465

In Europe: +32 3 450 2240; Fax: +32 3 450 2815

In The Pacific: +886-2-25478732; Fax: +886-2-27174115

In Other Global Areas: 1-989-832-1560; Fax: 1-989-832-1465

www.dowtherm.com

NOTICE: No freedom from any patent owned by Seller or others is to be inferred. Because use conditions and applicable laws may differ from one location to another and may change with time, Customer is responsible for determining whether products and the information in this document are appropriate for Customer's use and for ensuring that Customer's workplace and disposal practices are in compliance with applicable laws and other governmental enactments. Seller assumes no obligation or liability for the information in this document. NO WARRANTIES ARE GIVEN; ALL IMPLIED WARRANTIES OF MERCHANTABILITY OR FITNESS FOR A PARTICULAR PURPOSE ARE EXPRESSLY EXCLUDED.

Published April 2002.

